

Service Guide

**Agilent Technologies
N9923A
FieldFox
RF Vector Network Analyzer
(2 MHz – 4 GHz)
(2 MHz – 6 GHz)**



Agilent Technologies

Part Number N9923-90018

Printed in USA

March 24, 2011

Supersedes: December 14, 2010

© Agilent Technologies, Inc. 2010, 2011

Warranty Statement

THE MATERIAL CONTAINED IN THIS DOCUMENT IS PROVIDED “AS IS,” AND IS SUBJECT TO BEING CHANGED, WITHOUT NOTICE, IN FUTURE EDITIONS. FURTHER, TO THE MAXIMUM EXTENT PERMITTED BY APPLICABLE LAW, AGILENT DISCLAIMS ALL WARRANTIES, EITHER EXPRESS OR IMPLIED WITH REGARD TO THIS MANUAL AND ANY INFORMATION CONTAINED HEREIN, INCLUDING BUT NOT LIMITED TO THE IMPLIED WARRANTIES OF MERCHANTABILITY AND FITNESS FOR A PARTICULAR PURPOSE. AGILENT SHALL NOT BE LIABLE FOR ERRORS OR FOR INCIDENTAL OR CONSEQUENTIAL DAMAGES IN CONNECTION WITH THE FURNISHING, USE, OR PERFORMANCE OF THIS DOCUMENT OR ANY INFORMATION CONTAINED HEREIN. SHOULD AGILENT AND THE USER HAVE A SEPARATE WRITTEN AGREEMENT WITH WARRANTY TERMS COVERING THE MATERIAL IN THIS DOCUMENT THAT CONFLICT WITH THESE TERMS, THE WARRANTY TERMS IN THE SEPARATE AGREEMENT WILL CONTROL.

DFARS/Restricted Rights Notice

If software is for use in the performance of a U.S. Government prime contract or subcontract, Software is delivered and licensed as “Commercial computer software” as defined in DFAR 252.227-7014 (June 1995), or as a “commercial item” as defined in FAR 2.101(a) or as “Restricted computer software” as defined in FAR 52.227-19 (June 1987) or any equivalent agency regulation or contract clause. Use, duplication or disclosure of Software is subject to Agilent Technologies’ standard commercial license terms, and non-DOD Departments and Agencies of the U.S. Government will receive no greater than Restricted Rights as defined in FAR 52.227-19(c)(1-2) (June 1987). U.S. Government users will receive no greater than Limited Rights as defined in FAR 52.227-14 (June 1987) or DFAR 252.227-7015 (b)(2) (November 1995), as applicable in any technical data.

Certification

Agilent Technologies, Inc. certifies that this product met its published specifications at the time of shipment from the factory. Agilent Technologies, Inc. further certifies that its calibration measurements are traceable to the United States National Institute of Standards and Technology, to the extent allowed by the Institute's calibration facility, and to the calibration facilities of other International Standards Organization members.

Assistance

Product maintenance agreements and other customer assistance agreements are available for Agilent Technologies, Inc. products. For information about these agreements and for other assistance, contact Agilent. Refer to [“Contacting Agilent” on page 2-6](#).

Safety and Regulatory Information

The safety and regulatory information pertaining to this product is located in [Chapter 1, “Safety and Regulatory Information.”](#)

Safety Notes

The following safety notes are used throughout this manual. Familiarize yourself with each of the notes and its meaning before operating this instrument. All pertinent safety notes for using this product are located in [Chapter 1, “Safety and Regulatory Information.”](#)

WARNING	Warning denotes a hazard. It calls attention to a procedure which, if not correctly performed or adhered to, could result in injury or loss of life. Do not proceed beyond a warning note until the indicated conditions are fully understood and met.
----------------	---

CAUTION	Caution denotes a hazard. It calls attention to a procedure that, if not correctly performed or adhered to, could result in damage to or destruction of the instrument. Do not proceed beyond a caution sign until the indicated conditions are fully understood and met.
----------------	---

Supplemental Information

Supplemental information for this service guide is available at:

http://na.tm.agilent.com/fieldfox/serv_guide_supplement.html

This web site contains additional service information and is updated as new information becomes available.

Contents

1 Safety and Regulatory Information

Information in This Chapter	1-2
Chapter One at-a-Glance	1-2
Safety Symbols	1-3
General Safety Considerations	1-3
Safety Earth Ground	1-3
Before Applying Power	1-4
Servicing	1-4
Electrostatic Discharge Protection	1-5
Regulatory Information	1-6
Instrument Markings	1-6
Battery Disposal	1-7

2 General Product Information

Information in This Chapter	2-2
Chapter Two at-a-Glance	2-2
Maintenance	2-3
Physical Maintenance	2-3
Electrical Maintenance	2-3
Analyzer Options	2-3
Frequency Range Options	2-3
Network Analyzer (NA) Options	2-3
Power Meter (PM) Option	2-4
Cable and Antenna Test (CAT) Option	2-4
Vector Voltmeter (VVM) Option	2-4
Agilent Support, Services, and Assistance	2-5
Service and Support Options	2-5
Calibration Options	2-5
Contacting Agilent	2-6
Shipping Your Analyzer to Agilent for Service or Repair	2-6
Printing Copies of Documentation from the Web	2-6

3 Tests and Adjustments

Information in This Chapter	3-2
Chapter Three at-a-Glance	3-2
Before You Begin	3-3
Protect Against Electrostatic Discharge (ESD)	3-3
Allow the Analyzer to Warm Up	3-3
Review the Principles of Connector Care	3-4
Service Test Equipment	3-5
Before Returning an Instrument to a Customer	3-6
Operational Check	3-6
Performance Tests and Adjustments	3-7
Performance Tests	3-7
Adjustments	3-8
Test Software and Information Available on the Web	3-8
TME Downloads	3-8
Agilent FieldFox Customer Support Web Pages	3-8

Contents

4 Troubleshooting	
Information in This Chapter	4-2
Chapter Four at-a-Glance	4-2
Protect Against Electrostatic Discharge (ESD)	4-3
Assembly Replacement Sequence	4-3
Getting Started with Troubleshooting	4-4
Check the Basics	4-4
Troubleshooting Organization	4-5
Power Up Troubleshooting	4-6
Front Panel Group Troubleshooting	4-7
Measurement Group Troubleshooting	4-8
5 Theory of Operation	
Information in This Chapter	5-2
Chapter Five at-a-Glance	5-2
Analyzer System Operation	5-3
Functional Groups of the Analyzer	5-3
Front Panel Group	5-5
A3 Front Panel Interface Board	5-5
A2 LCD Assembly	5-6
Measurement Group	5-7
A4 RF Board	5-7
A5 System Board	5-10
A6 SOM Board	5-13
Main Battery	5-13
Grounding and Power	5-14
Grounding	5-14
Voltages and Power Supplies	5-14
Power Control and Management	5-15
Battery Related Information	5-16
Operation in Modes	5-18
CAT, NA, and VMM Modes	5-19
Power Meter Mode	5-19
Temperature Related Information	5-20
User Calibration in CAT and NA Modes	5-21
Factory Calibration	5-21
QuickCal	5-21
User Calibration	5-22
Firmware Related Information	5-23
General Description	5-23
User Accessible Files	5-23
Operational Files	5-23
Erase User Data Utility	5-23
Error Log	5-24
Firmware Upgrades	5-24
LAN Interface	5-25

6 Replaceable Parts

Information in This Chapter	6-2
Chapter Six at-a-Glance	6-2
Ordering Information	6-3
Assembly Replacement Procedure	6-4
Replaceable Parts Listings	6-5
Entire Analyzer	6-5
Front Panel Group	6-6
Measurement Group	6-8
Case Group	6-10
Miscellaneous Parts	6-12

7 Repair and Replacement Procedures

Information in This Chapter	7-2
Chapter Seven at-a-Glance	7-2
Personal Safety Warnings	7-3
Safety Earth Ground	7-3
Electrostatic Discharge (ESD) Protection	7-3
Assembly Replacement Sequence	7-4
Removal and Replacement Procedures	7-4
Removing and Replacing the Main Battery	7-5
Removing and Replacing the Case Group Parts	7-6
Removing and Replacing the Front Panel Group Assemblies	7-18
Removing and Replacing the Measurement Group Assemblies	7-25
Post-Repair Procedures	7-37
Manual Checks and Procedures	7-38

8 General Purpose Maintenance and Service Procedures

Information in This Chapter	8-2
Chapter Eight at-a-Glance	8-2
Supplemental Information	8-3
Service Related User Operations	8-3
To View Currently Installed Options	8-3
To View the Current Firmware Revision, Etc.	8-3
To View the Error Log	8-3
To View Temperature Readings	8-4
Erase User Data Utility	8-4
Options	8-5
To View Currently Installed Options	8-5
Re-Installing Options	8-5
Firmware Upgrades	8-6
To Check the Current Firmware Revision	8-6
Miscellaneous Service and Maintenance	8-7
Cleaning the Display	8-7
Battery Maintenance	8-7

1 Safety and Regulatory Information

Information in This Chapter

This chapter provides safety information that will help protect you and your network analyzer. It also contains information that is required by various government regulatory agencies.

Chapter One at-a-Glance

Section Title	Summary of Content	Start Page
Safety Symbols	Descriptions of CAUTION and WARNING symbols used throughout this manual.	Page 1-3
General Safety Considerations	A list of safety points to consider when servicing your network analyzer.	Page 1-3
Electrostatic Discharge Protection	A discussion of electrostatic discharge (ESD) and related recommendations and requirements for ESD protection.	Page 1-5
Regulatory Information	Definitions of instrument markings. Instructions for disposing of the analyzer's lithium battery.	Page 1-6

Safety Symbols

The following safety symbols are used throughout this manual. Familiarize yourself with each of the symbols and its meaning before operating this instrument.

CAUTION Caution denotes a hazard. It calls attention to a procedure that, if not correctly performed or adhered to, could result in damage to or destruction of the instrument. Do not proceed beyond a caution note until the indicated conditions are fully understood and met.

WARNING **Warning denotes a hazard. It calls attention to a procedure which, if not correctly performed or adhered to, could result in injury or loss of life. Do not proceed beyond a warning note until the indicated conditions are fully understood and met.**

General Safety Considerations

Safety Earth Ground

WARNING **This is a Safety Class I product (provided with a protective earthing ground incorporated in the power cord). The mains plug shall only be inserted in a socket outlet provided with a protective earth contact. Any interruption of the protective conductor, inside or outside of the instrument, will make the instrument dangerous. Intentional interruption is prohibited.**

CAUTION Always use the three-prong AC power cord supplied with this product. Failure to ensure adequate grounding by not using this cord may cause product damage.

Before Applying Power

WARNING If this product is not used as specified, the protection provided by the equipment could be impaired. This product must be used in a normal condition (in which all means for protection are intact) only.

CAUTION This product is designed for use in Installation Category II and Pollution Degree 2 per IEC 61010-1:2001 and 664 respectively.

CAUTION The measuring terminals on this instrument are designed to be used with external signals described in Measurement Category I, but NOT with external signals described in Categories II, III, and IV. The input of this instrument cannot be connected to the mains.

Servicing

WARNING These servicing instructions are for use by qualified personnel only. To avoid electrical shock, do not perform any servicing unless you are qualified to do so.

WARNING Danger of explosion if battery is incorrectly replaced. Replace only with the same or equivalent type recommended. Discard used batteries according to local ordinances and/or manufacturer's instructions.

WARNING No operator serviceable parts inside. Refer servicing to qualified personnel. To prevent electrical shock, do not remove covers.

WARNING For continued protection against fire hazard, replace line fuse only with same type and rating. The use of other fuses or material is prohibited.

WARNING The detachable power cord is the instrument disconnecting device. It disconnects the mains circuits from the mains supply before other parts of the instrument. The front panel switch is only a standby switch and is not a LINE switch (disconnecting device).

Electrostatic Discharge Protection

Protection against electrostatic discharge (ESD) is essential while removing assemblies from or connecting cables to the network analyzer. Static electricity can build up on your body and can easily damage sensitive internal circuit elements when discharged. Static discharges too small to be felt can cause permanent damage. To prevent damage to the instrument:

- *always* have a grounded, conductive table mat in front of your test equipment.
- *always* wear a grounded wrist strap, connected to a grounded conductive table mat, having a 1 M Ω resistor in series with it, when handling components and assemblies or when making connections.
- *always* wear a heel strap when working in an area with a conductive floor. If you are uncertain about the conductivity of your floor, wear a heel strap.
- *always* ground yourself before you clean, inspect, or make a connection to a static-sensitive device or test port. You can, for example, grasp the grounded outer shell of the test port or cable connector briefly.
- *always* ground the center conductor of a test cable before making a connection to the analyzer test port or other static-sensitive device. This can be done as follows:
 1. Connect a short (from your calibration kit) to one end of the cable to short the center conductor to the outer conductor.
 2. While wearing a grounded wrist strap, grasp the outer shell of the cable connector.
 3. Connect the other end of the cable to the test port and remove the short from the cable.

Figure 1-1 shows a typical ESD protection setup using a grounded mat and wrist strap. Refer to “ESD Supplies” on page 6-12 for part numbers.

Figure 1-1 ESD Protection Setup

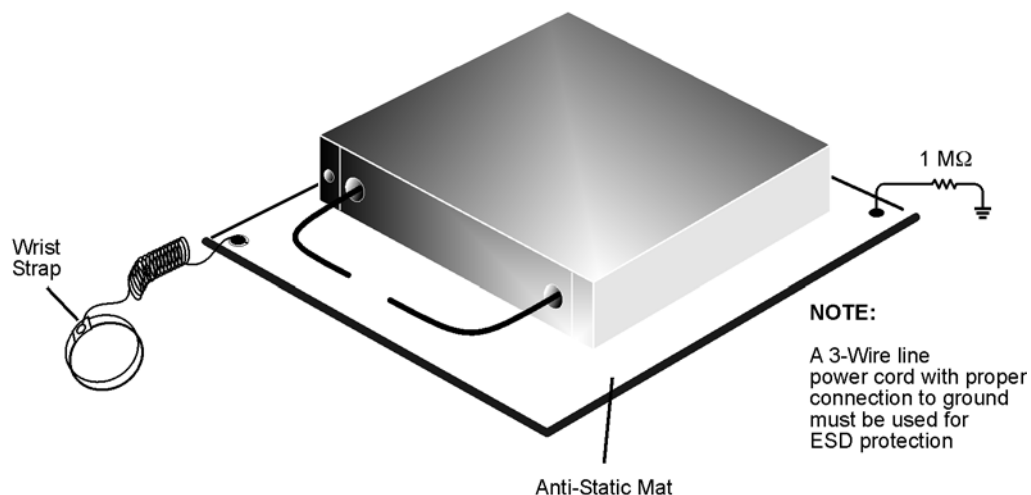

esd_setup

Regulatory Information

This section contains information that is required by various government regulatory agencies.

Instrument Markings



The instruction documentation symbol. The product is marked with this symbol when it is necessary for the user to refer to the instructions in the documentation.



The CE mark is a registered trademark of the European Community. (If accompanied by a year, it is when the design was proven.)



The CSA mark is a registered trademark of the Canadian Standards Association.

ICES/NMB-001

This is a marking to indicate product compliance with the Canadian Interference-Causing Equipment Standard (ICES-001).

ISM1-A

This is a symbol of an Industrial Scientific and Medical Group 1 Class A product.



This is a required mark signifying compliance with an EMC requirement. The C-Tick mark is a registered trademark of the Australian Spectrum Management Agency.



This product complies with the WEEE Directive (2002/96/EC) marking requirements. The affixed label indicates that you must not discard this electrical/ electronic product in domestic household waste.

Product Category: With reference to the equipment types in the WEEE Directive Annex I, this product is classed as a "Monitoring and Control instrumentation" product.

Do not dispose in domestic household waste.

To return unwanted products, contact your local Agilent office, or see <http://www.agilent.com/environment/product/> for more information.

Battery Disposal

If either the primary power battery, or the RTC (real time clock) battery (on the A3 front panel interface board) needs to be disposed of, dispose of it in accordance with your country's requirements. If required, you may return the battery to Agilent Technologies for disposal. Refer to [“Contacting Agilent” on page 2-6](#) for assistance.



DO NOT THROW BATTERIES AWAY BUT
COLLECT AS SMALL CHEMICAL WASTE.

For instructions on removing and replacing the primary power battery, refer to [“Removing and Replacing the Main Battery” on page 7-5](#).

For instructions on removing and replacing the RTC (real time clock) battery located on the A3 front panel interface board, refer to [“Replacing the A3 Front Panel Interface Board \(FPIB\)” on page 7-22](#).

2 General Product Information

Information in This Chapter

Chapter Two at-a-Glance

Section Title	Summary of Content	Start Page
Maintenance	Cleaning instructions for the external surfaces of your analyzer. Information about electrical maintenance of your analyzer.	Page 2-3
Analyzer Options	A list of the options available for the microwave network analyzers.	Page 2-3
Agilent Support, Services, and Assistance	The Internet address (URL) for Agilent assistance. Service and support options available. Calibration options available. Important information about shipping your analyzer to Agilent for service or repair.	Page 2-5

Maintenance

WARNING To prevent electrical shock, disconnect the analyzer from the mains source before cleaning. Use a dry cloth or one slightly dampened with water to clean the external case parts. Do not attempt to clean internally.

Physical Maintenance

Clean the analyzer case using a dry or slightly damp cloth only.

Electrical Maintenance

Refer to “Contacting Agilent” on page 2-6 and to Chapter 3, “Tests and Adjustments.”

Analyzer Options

Below is a list of options available for the FieldFox N9923A. Additional options may be added as product features are enhanced. Go to www.agilent.com/find/fieldfox2 for information on currently available upgrade options.

The base model for the N9923A includes option 104.

Frequency Range Options

Option 104, 2 MHz to 4 GHz Frequency Range

This option allows you to make measurements in the 2 MHz to 4 GHz frequency range.

Option 106, 2 MHz to 6 GHz Frequency Range

This option allows you to make measurements in the 2 MHz to 6 GHz frequency range.

Network Analyzer (NA) Options

Option 122, Full 2-Port S-Parameters

The standard vector network analyzer allows you to make S11 and S21 measurements. Option 122 allows you to make S11, S12, S21, S22, A, B, R1, and R2 measurements.

Option 112, QuickCal

This option provides a calibration that is performed automatically using calibration standards that are built-in to the N9923A. Calibration standards are automatically switched in as needed. QuickCal is ideal for making quick DTF and cable loss measurements without taking the time to perform a full O,S,L Cal.

Power Meter (PM) Option

Option 302, Power Meter Mode

This option allows you to use Agilent external USB power sensors to make power measurements.

Cable and Antenna Test (CAT) Option

Option 305, Cable and Antenna Test Mode

This option allows you to make the following cable and antenna measurements:

- Distance-to-Fault (DTF)
- DTF and Return Loss
- Return Loss (dB)
- VSWR
- DTF (VSWR)
- Cable Loss (1-port)
- Insertion Loss (2-port)

Vector Voltmeter (VVM) Option

Option 308, Vector Voltmeter Mode

This option allows you to make the following measurements:

- 1-port cable trimming (magnitude and phase)
- 2-port transmission (magnitude only)

Agilent Support, Services, and Assistance

Information on the following topics is included in this section.

- [“Service and Support Options”](#)
- [“Calibration Options”](#)
- [“Contacting Agilent”](#)
- [“Shipping Your Analyzer to Agilent for Service or Repair”](#)

Service and Support Options

The analyzer’s standard warranty is a *one-year return to Agilent Technologies* service warranty.

NOTE	There are other repair and calibration options available from Agilent Technologies. Contact Agilent for additional information on available service agreements for this product. Refer to “Contacting Agilent” on page 2-6 .
-------------	--

Calibration Options

The calibration options listed below are supported by Agilent Technologies. The calibrations may be performed by Agilent Technologies or a qualified customer may perform the calibrations. See [Chapter 3](#) for details on testing the N9923A.

Commercial Calibration Certificate with Test Data

A complete set of measurements that test the analyzer to the manufacturer’s published specifications. It includes a calibration label, a calibration certificate, and the corresponding calibration data report. This calibration conforms to ISO 9001.

ISO 17025 Standards Compliant Calibration

A complete set of measurements that test the analyzer to the manufacturer’s published specifications. It includes a calibration label, an ISO 17025 calibration certificate, and the corresponding calibration data, measurement uncertainties, and guardbands on all customer specifications. This calibration conforms to ISO 17025 and ISO 9001.

This calibration option is available at the time of purchase or can be obtained later by sending your analyzer to Agilent for calibration. Refer to [“Shipping Your Analyzer to Agilent for Service or Repair”](#).

ANSI Z540 Standards Compliant Calibration

A complete set of measurements that test the analyzer to the manufacturer’s published specifications. It includes both pre- and post-adjustment data with measurement uncertainty information compliant to the ANSI/NCSL Z540 standard.

This calibration option is available at the time of purchase or can be obtained later by sending your analyzer to Agilent for calibration. Refer to [“Shipping Your Analyzer to Agilent for Service or Repair”](#).

Contacting Agilent

Assistance with test and measurements needs and information on finding a local Agilent office are available on the Web at: <http://www.agilent.com/find/assist>

If you do not have access to the Internet, please contact your Agilent field engineer.

NOTE In any correspondence or telephone conversation, refer to the Agilent product by its model number and full serial number. With this information, the Agilent representative can determine whether your product is still within its warranty period.

Shipping Your Analyzer to Agilent for Service or Repair

IMPORTANT Agilent Technologies reserves the right to reformat or replace the flash memory in your analyzer as part of its repair. This will erase all user information stored in the instrument. It is imperative, therefore, that you make a backup copy of your critical test data stored in the analyzer before shipping it to Agilent for repair.

If you wish to send your network analyzer to Agilent Technologies for service or repair:

- Include a complete description of the service requested or of the failure and a description of any failed test and any error message.
- Ship the analyzer using the original or comparable antistatic packaging materials.
- Contact Agilent for instructions on where to ship your analyzer. Refer to “[Contacting Agilent](#)” on page 2-6.

Printing Copies of Documentation from the Web

To print copies of documentation from the Web, download the PDF file from the Agilent web site:

- Go to <http://www.agilent.com>.
- Enter the document’s part number (located on the title page) in the Search box.
- Click **Search**.

3 Tests and Adjustments

Information in This Chapter

This chapter contains procedures to help you check, verify, and adjust your N9923A analyzer.

- The checks verify the operation of the assemblies in your analyzer.
- The adjustments allow you to tune your analyzer for maximum response.

NOTE The Agilent N7841A software package will be required to test and adjust your analyzer. See the section titled [“Performance Tests and Adjustments”](#) farther on in this chapter for details.

Chapter Three at-a-Glance

Section Title	Summary of Content	Start Page
Before You Begin	Items to consider or procedures to perform before testing is begun: <ul style="list-style-type: none">• Verify the operating environment.• Protect Against Electrostatic Discharge (ESD)• Allow the Analyzer to Warm Up• Review the Principles of Connector Care	Page 3-3
Service Test Equipment	A list of additional equipment recommended for servicing the N9923A analyzer.	Page 3-5
Before Returning an Instrument to a Customer	A list of things to do before returning an instrument to a customer after servicing is completed.	Page 3-6
Operational Check	An operation check that should be performed before returning an instrument to a customer.	Page 3-6
Performance Tests and Adjustments	A list of performance tests and adjustments for the N9923A included in the Agilent N7841A software package.	Page 3-7

Before You Begin

Before checking, verifying, or adjusting the analyzer, refer to the following paragraphs to:

- Make sure the operating environment is within 19 to 27 °C and 5 to 95% humidity.
- Make sure that proper electrostatic discharge (ESD) protection is provided.
- Review the principles of connector care.

Protect Against Electrostatic Discharge (ESD)

This is important. If not properly protected against, electrostatic discharge can seriously damage your analyzer, resulting in costly repair.

CAUTION To reduce the chance of electrostatic discharge, follow all of the recommendations outlined in [“Electrostatic Discharge Protection” on page 1-5](#), for all of the procedures in this chapter.

Allow the Analyzer to Warm Up

Before testing or adjusting the N9923A analyzer, allow it to warm up as described under “UUT Warmup” in the “Getting Started” section of the N7841A help file.

Review the Principles of Connector Care

Proper connector care and connection techniques are critical for accurate and repeatable measurements. Refer to [Table 3-1](#) for tips on connector care.

Prior to making connections to your analyzer, carefully review the information about inspecting, cleaning, and gaging connectors. Refer to the calibration kit documentation for detailed connector care information.

For course numbers about additional connector care instruction, contact Agilent Technologies. Refer to [“Contacting Agilent” on page 2-6](#).

Table 3-1 Connector Care Quick Reference Guide

Handling and Storage	
Do <ul style="list-style-type: none"> • Keep connectors clean • Extend sleeve or connector nut • Use plastic end-caps during storage 	Do Not <ul style="list-style-type: none"> • Touch mating-plane surfaces • Set connectors contact-end down • Store connectors or adapters loose
Visual Inspection	
Do <ul style="list-style-type: none"> • Inspect all connectors carefully • Look for metal particles, scratches, and dents 	Do Not <ul style="list-style-type: none"> • Use a damaged connector - ever
Connector Cleaning	
Do <ul style="list-style-type: none"> • Try compressed air first • Use isopropyl alcohol^a • Clean connector threads 	Do Not <ul style="list-style-type: none"> • Use any abrasives • Get liquid into plastic support beads
Gaging Connectors	
Do <ul style="list-style-type: none"> • Clean and zero the gage before use • Use the correct gage type • Use correct end of calibration block • Gage all connectors before first use 	Do Not <ul style="list-style-type: none"> • Use an out-of-specification connector
Making Connections	
Do <ul style="list-style-type: none"> • Align connectors carefully • Make preliminary connection contact lightly • Turn only the connector nut • Use a torque wrench for final connection 	Do Not <ul style="list-style-type: none"> • Apply bending force to connection • Over tighten preliminary connection • Twist or screw any connection • Tighten past torque wrench “break” point

- a. Cleaning connectors with alcohol shall only be done with the instrument’s power cord removed, and in a well-ventilated area. Allow all residual alcohol moisture to evaporate, and the fumes to dissipate prior to energizing the instrument.

Service Test Equipment

The test equipment required for the TME based N7841A test and adjustment software is listed in the N7841A help file.

The following additional test equipment is recommended when servicing the N9923A analyzer:

- **Main Battery**—Required if the analyzer is returned for service without a battery. Refer to [Table 6-1 on page 6-12](#) for part numbers.
- **USB flash drive**—Used for firmware upgrades, option installation, etc. Also known as USB memory stick. Must be 128 MB or larger.
- **Small, free-standing fan**—Used to cool the analyzer if internal temperature is too high. See “UT Warmup” in the “Getting Started” section of the N7841A help file for usage instructions. Generic small office fan of approximately six inches in diameter is sufficient.
- **Type-N male cal kit**—Tee cal kit, part number 1250-3607, is recommended.
- **Micro SD flash card**—Required to re-load firmware onto the A6 SOM board. A “micro” physical sized Secure Digital (SD) flash memory card is required. This card is not available from Agilent. To identify a supplier, search the Web for “micro sd card”.
- **Stereo headphones or ear buds**—May be used to troubleshoot sound output if there is a problem with the internal speaker.

Before Returning an Instrument to a Customer

When finished servicing an N9923A analyzer, perform the following before returning the unit to the customer:

- Set the **Display Colors** to **Indoors** and the display **Brightness** to 80% via **Service (7) > Display**.
- Perform an Operational Check as described in the following section.
- Connect and disconnect the external battery charger while the N9923A is operating and confirm that the power cord icon is displayed appropriately at the top of the display.
- Charge the battery to 80% or higher.

Operational Check

1. Preset the instrument, press **Preset (.) > Preset**.
2. Leave the PORT 1 and Port 2 connectors open.
3. Press: **Scale/Amptd > Ref Pos > 2 > Enter**
4. Press: **Scale > 1 > Enter**
5. The trace should be between -1 and +1 dB. (S11 is displayed.)
6. Press: **Measure**
7. If the S22 soft key exists, press it to display S22.
 - a. The trace should be between -1 and +1 dB.

NOTE If the operational check fails, allow the instrument to warm up for 15 minutes and try again.

Performance Tests and Adjustments

The performance tests and adjustments listed below support the N9923A analyzer. The Agilent N7841A TME software application supports these tests and adjustments.

The Agilent N7841A TME software application executes on a PC under the Agilent N7800A test executive. See [“TME Downloads” on page 3-8](#) for applicable web links.

The N7841A Help provides troubleshooting recommendations when a performance test or adjustment fails.

A description of each of the performance tests and adjustments for the N9923A follows.

Performance Tests

Frequency Accuracy

This test measures the accuracy of the internal time base by measuring the frequency at Port 1. A 1.8 GHz low pass filter is used to attenuate harmonics generated by the source in the UUT.

Error Terms

This test checks the quality of the CalReady calibration. It measures a short connected to the port under test.

Note: The Error Terms adjustment should be performed every twelve months to preserve calibration accuracy for CalReady.

System Dynamic Range

This test performs a two port isolation calibration which sets the reference power to the power output level of each port (0 dB = the power output level at the port). Loads are then connected to each port. The S21 and S12 measurements then represent the difference between the port output power and the noise floor for a given measurement. Averaging is used to remove random noise.

Receiver Compression

This test measures compression at +10 dBm over a range of frequencies. Power deltas measured by the FieldFox A and B receivers are compared to power deltas measured by a power meter. This measurement is relative to the 0 dBm reference.

Dynamic Accuracy

The Z5623A H01 test set is used to measure dynamic accuracy of the A and B receivers down to -41 dBm. A reference power of -1 dBm is used for the test.

Adjustments

Frequency Accuracy

Locks to Ext Ref 10 MHz signal via DAC. Stores DAC setting to use when not in External Reference mode.

Phase Lock Accelerator

This process creates factors for various phase lock capture speeds used during measurements. No test equipment is required.

Error Terms

This adjustment process updates the correction information used by CalReady (i.e. the Factory Cal). It uses an ECal to perform a one port cal on each port, then completes a two port cal using the thru and loads.

Note: The Error Terms adjustment should be performed every twelve months to preserve calibration accuracy of CalReady.

Test Software and Information Available on the Web

TME Downloads

Information and download links for the N7841A application are available at www.agilent.com/find/calibrationsoftware. This web site provides links for downloading software and user instructions. Note that the N7800A software must be installed prior to installing the N7841A and it requires a separate license.

The web page for the N7841A download also provides a link to the N7841A help. This help system provides user instructions and lists of required equipment. It may be accessed prior to downloading the software.

Agilent FieldFox Customer Support Web Pages

The following URL provides updated help and additional information for using TME with FieldFox. Consult it for the most up-to-date information.

http://na.tm.agilent.com/fieldfox/tme_info.html

4 Troubleshooting

Information in This Chapter

The information in this chapter helps you:

- Identify the portion of the analyzer at fault.
- Locate the specific troubleshooting procedure to identify the assembly or peripheral at fault.

The sections in this chapter are arranged in a logical troubleshooting order. The following table lists the sections and a brief summary of what to look for in that section.

Chapter Four at-a-Glance

Section Title	Summary of Content	Start Page
'Getting Started with Troubleshooting'	A starting point to begin troubleshooting.	Page 4-4
'Power Up Troubleshooting'	Power-up problems: <ul style="list-style-type: none">• Power supply problems	Page 4-6
'Front Panel Group Troubleshooting'	<ul style="list-style-type: none">• Problems with the front panel assemblies of the analyzer.	Page 4-7
'Measurement Group Troubleshooting'	Problems with the measurement group assemblies of the analyzer.	Page 4-8

Protect Against Electrostatic Discharge (ESD)

This is important. If not properly protected against, electrostatic discharge can seriously damage your analyzer, resulting in costly repair.

CAUTION To reduce the chance of electrostatic discharge, follow all of the recommendations outlined in [“Electrostatic Discharge Protection” on page 1-5](#), for all of the procedures in this chapter.

Assembly Replacement Sequence

After identifying the problem requiring an assembly to be replaced, follow these steps:

- Step 1.** Order a replacement assembly. Refer to [Chapter 6, “Replaceable Parts.”](#)
- Step 2.** Replace the faulty assembly and determine what adjustments are necessary. Refer to [Chapter 7, “Repair and Replacement Procedures.”](#)
- Step 3.** Perform the necessary adjustments. Refer to [Chapter 3, “Tests and Adjustments.”](#)
- Step 4.** Perform the necessary performance tests. Refer to [Chapter 3, “Tests and Adjustments.”](#)

Getting Started with Troubleshooting

Where you begin troubleshooting depends upon the symptoms of the failure. If a performance test or adjustment fails, refer to the troubleshooting recommendations in the N7841A Help. For other failures, start by checking the basics as outlined in the following section. Also review the flowchart in [Figure 4-1 on page 4-5](#). You should then be able to determine where in the troubleshooting procedure to begin, to locate the failed assembly.

Check the Basics

A problem can often be solved by repeating the procedure you were following when the problem occurred. Before calling Agilent Technologies or returning the instrument for service, please perform the following checks:

1. Does the analyzer have power available? It is recommended that the battery is installed and the AC power adapter is also connected.
2. Does the analyzer turn On and Off when the On/Off Button is pressed? When the unit is on, the green LED below the button should light.
3. Does the analyzer power up normally into CAT mode? If not, see [“Power Up Troubleshooting” on page 4-6](#).
4. If other equipment, cables, and connectors are being used with the analyzer, make sure they are clean, connected properly and operating correctly.
5. Review the procedure for the measurement being performed when the problem appeared. Are all the settings correct? If not, correct them.
6. If the analyzer is not functioning as expected, return it to a known state by pressing the **Preset** key.
7. If the problem is thought to be due to firmware, check to see if the instrument has the latest firmware before starting the troubleshooting procedure. Refer to [“Firmware Upgrades” in Chapter 8](#) for instructions.

Troubleshooting Organization

Follow the flowgraph in [Figure 4-1](#) to help direct you to the correct section for troubleshooting the analyzer.

Figure 4-1 Troubleshooting Organization Flowchart

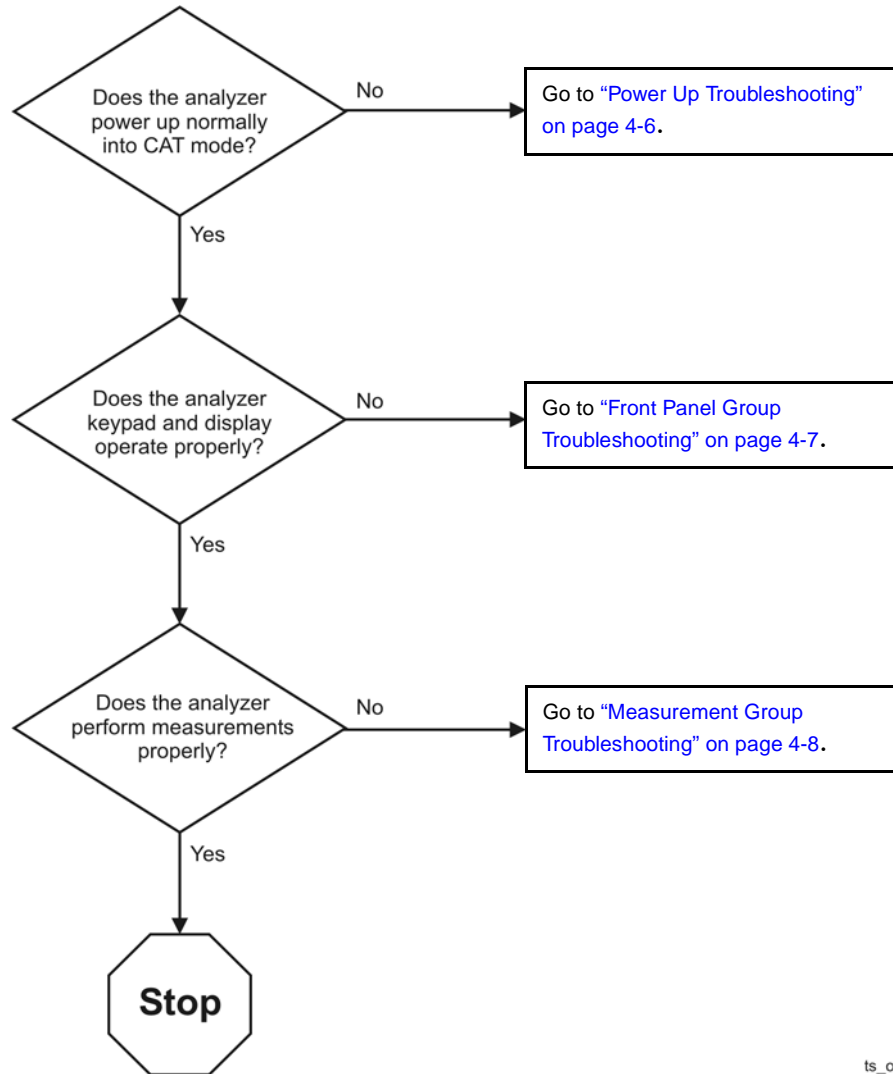

ts_org

Power Up Troubleshooting

If the display is operational but the unit does not boot up successfully into CAT mode:

- Make sure there is sufficient power for the unit to operate.
- Try re-installing firmware using the firmware upgrade process described in [Chapter 8](#).
- Assume corrupted firmware on the A6 SOM board, follow the “[Install Firmware from SD Card](#)” near the end of [Chapter 7](#).

If the display is dark but the unit may have booted successfully:

- Wait for two minutes to make sure the boot process has completed, then press any front panel key.

If the boot process has completed successfully, the keypad will flash when the key is pressed.

Front Panel Group Troubleshooting

If no sound:

- Enter a value of just “.” (decimal point) for a frequency.

A double beep should occur. Plug headphones into the unit if there is no sound from the internal speaker. The internal speaker is disabled when headphones are plugged in.

If the display is dark (no backlight):

- Press: Mode > System(7) > the left-most soft key > the next to the left-most soft key > press the up arrow many times.

This should bring the display brightness setting to a viewable level.

Measurement Group Troubleshooting

If calibration with the standard Type-N cal kit (1250-3607 or N9910X-800) gives unexpected results:

- Make sure the unit is warmed up for at least 30 minutes.
- Make sure the correct cal kit definition is being used; erase user data to force use of factory cal kit definitions (see [Chapter 8](#) for information on the “[Erase User Data Utility](#)”).

5 Theory of Operation

Information in This Chapter

This chapter provides a general description of the operating theory of the N9923A analyzer.

- Theory of operation is explained to the assembly level only.
- Component-level circuit theory is not provided.
- Simplified block diagrams are included for each functional group.

Chapter Five at-a-Glance

Section Title	Summary of Content	Start Page
Analyzer System Operation	A summary of the theory of operation for the analyzer. A summary of the operation of the major functional groups of the analyzer.	Page 5-3
Front Panel Group	Operation of the assemblies associated with the front panel group of assemblies.	Page 5-5
Measurement Group	Operation of the assemblies associated with the measurement group of assemblies.	Page 5-7
Operation in Modes	Description of the different operating modes and what hardware is used in each mode.	Page 5-18
Temperature Related Information	Information about temperature sensors and how the analyzer responds to temperature information gathered.	Page 5-20
User Calibration in CAT and NA Modes	Descriptions of one port and two port calibrations for the CAT and NA modes of operation.	Page 5-21
Firmware Related Information	Information about firmware and firmware upgrades.	Page 5-23

Analyzer System Operation

The N9923A RF vector network analyzer operates as either a 1-port or 2-port network analyzer (NA). One port measurements are made using PORT 1 and two port measurements are made using both PORT 1 and PORT 2.

The NA function of the analyzer also supports cable and antenna test (CAT) functions.

See [Figure 5-1](#) for a simplified block diagram of the overall RF analyzer system.

All N9923A RF vector network analyzers have the same hardware. Options to increase functionality are enabled via licenses, additional hardware is not required.

Functional Groups of the Analyzer

The operation of the analyzer can be separated into two major functional groups. Each group consists of assemblies that perform distinct functions. Some of the assemblies are related to more than one group, and both groups, to some extent, are interrelated and affect each other's performance.

The major functional groups are:

- [Front Panel Group](#)
- [Measurement Group](#)

Front Panel Group

The front panel group consists of the following:

- [A2 LCD Assembly](#)
- [A3 Front Panel Interface Board](#)

Measurement Group

The measurement group consists of the following:

- [A4 RF Board](#)
- [A5 System Board](#)
- [A6 SOM Board](#)
- [Main Battery](#)

Figure 5-1 Overall Block Diagram

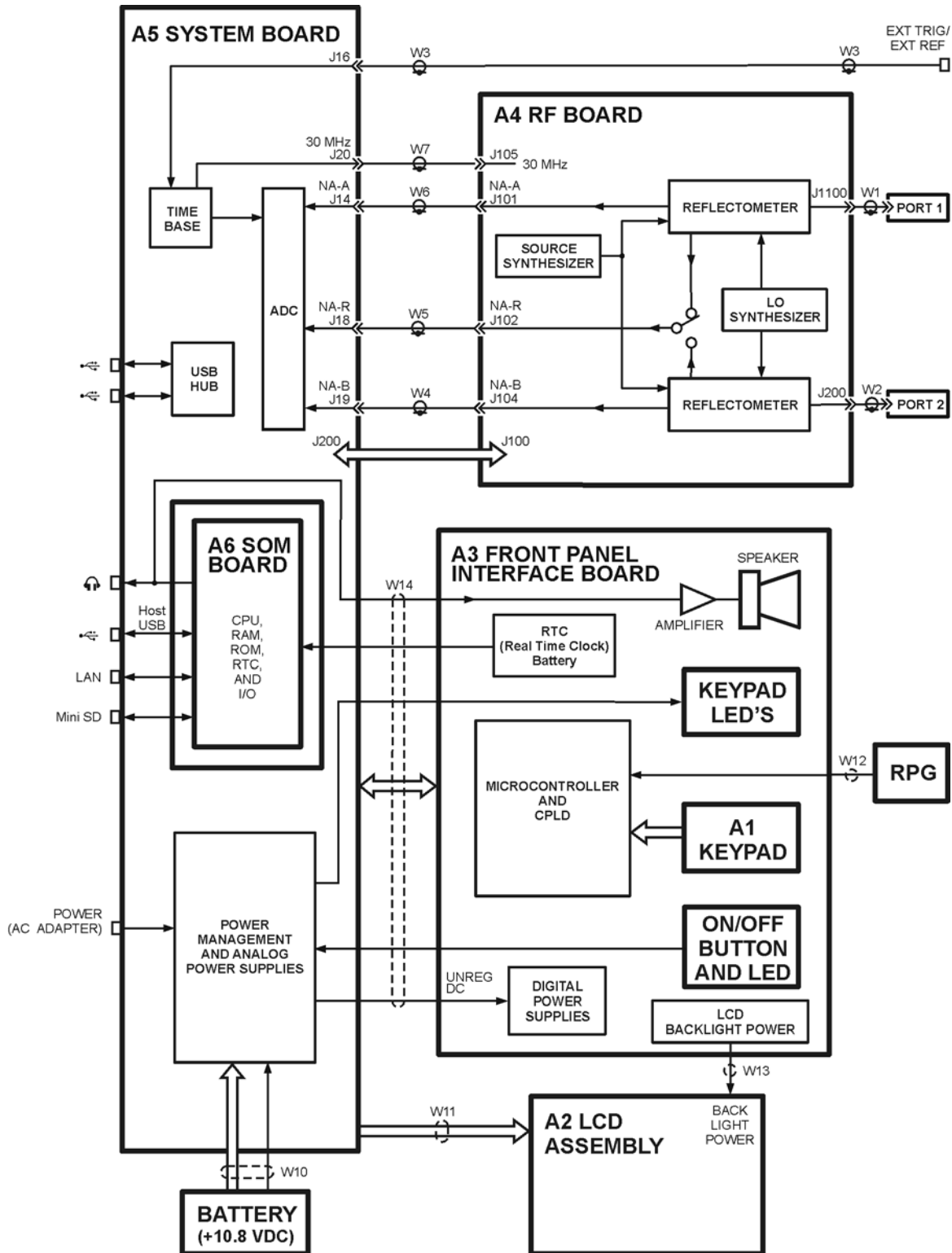

n9923a_overall_blk
 11 December 2010

Front Panel Group

The front panel group consists of the following assemblies:

- [A3 Front Panel Interface Board](#)
- [A2 LCD Assembly](#)

Refer to [Figure 5-1](#) for a simplified overall block diagram which includes the front panel group.

A3 Front Panel Interface Board

The main function of the A3 front panel interface board is to support the user interface but it also contains the digital power supplies.

Microcontroller and CPLD

The Microcontroller and CPLD sense the keypad keys and the RPG (rotary pulse generator) knob on the front panel. The Microcontroller communicates with the A5 system board via a USB interface.

There is no separate ID EPROM on the A3 front panel interface board. All ID information is stored in the Microcontroller.

Front Panel LED's and ON/OFF Button

The power for the Keypad LED's generated on the A3 front panel interface board is derived from the +5 V digital supply. The Keypad LED's are turned on for a few seconds following each key press. This function is controlled by the firmware on the A6 SOM board.

The On/Off LED is controlled by a signal from the A5 system board. The connections for the On/Off Button and LED are direct to the A5 system board.

Real Time Clock Battery

The battery for the RTC (real time clock) on the A6 SOM board is located on the A3 front panel interface board and is connected to the A6 SOM board via the A5 system board.

Backlight Power

Power for the backlight on the A2 LCD assembly is generated on the A3 front panel interface board. Digital 5 volts is converted to approximately 25 volts. The actual voltage determines the brightness of the backlight. Two control lines from the A5 system board control on/off and intensity functions. These control lines are driven by the system monitor microcontroller on the A5 system board.

Speaker and Headphones

The speaker is located on the A3 front panel interface board. Left and right audio signals from the A6 SOM board go to the headphone jack on the A5 system board. These signals are then combined (on the A5 system board) to create a single mono signal for the speaker. An amplifier on the A3 front panel interface board drives the speaker. Plugging in the headphones disables the speaker output.

Digital Power Supplies

Digital power supplies on the A3 front panel interface board are driven by the Unreg DC voltage from the A5 system board.

The 5 volts produced is used on the A3 front panel interface board and the A5 system board.

The 3.5 volts produced is used on the A3 front panel interface board, the A5 system board, and the A6 SOM board.

Both supplies are either on or off together except for power supply sequencing and are controlled by the System Monitor Microcontroller on the A5 system board.

A2 LCD Assembly

The A2 LCD assembly contains a 6.5-inch, 640 x 480 TFT color LCD with associated drive circuitry and backlight inverter.

The LCD backlight is created by LED's connected in parallel stacks. Backlight brightness is a function of the backlight power that ranges from 22 to 27 volts. Refer to [“Backlight Power” on page 5-5](#) for more information.

The backlight LED's are arranged along the top and bottom edges of the display. There are three stacks on each edge.

Measurement Group

The measurement group produces a stable output signal by phase locking a synthesized voltage-controlled oscillator (VCO).

The measurement group consists of the:

- [A4 RF Board](#)
- [A5 System Board](#)
- [A6 SOM Board](#)
- [Main Battery](#)

A simplified RF block diagram is provided in [Figure 5-2](#).

A simplified system block diagram is provided in [Figure 5-3](#).

A4 RF Board

The basic function of the A4 RF board is to provide a signal source and receivers for the analyzer functions.

An LO synthesizer produces a single LO signal from the 30 MHz time base located on the A5 system board. The LO output is delivered to the NA mixers of both ports.

The LO frequency is always above the measured frequency. The IF is 390 kHz.

The 30 MHz time base is also used to generate a source signal in the source synthesizer that covers the frequency range of 2 MHz to 6 GHz.

The source signal is generally rich in harmonic content. This is acceptable because the signal is used with tuned receivers.

The frequency bands for the RF board are listed below:

Band	Start Frequency ^a (MHz)	Stop Frequency (MHz)	Band	Start Frequency ^a (MHz)	Stop Frequency (MHz)
1	2.000	2.732	12	99.607	100.000
2	2.732	3.125	13	100.000	199.750
3	3.125	5.875	14	199.750	399.900
4	5.875	6.250	15	399.900	800.000
5	6.250	12.107	16	800.000	1600.000
6	12.107	12.500	17	1600.000	3200.000
7	12.500	24.607	18	3200.000	3399.000
8	24.607	25.000	19	3399.000	4149.705
9	25.000	49.607	20	4149.705	5099.705
10	49.607	50.000	21	5099.705	6000.000
11	50.000	99.607			

a. Except for band 1, start frequency is previous stop frequency +0.001 Hz.

Figure 5-2 Simplified RF Block Diagram

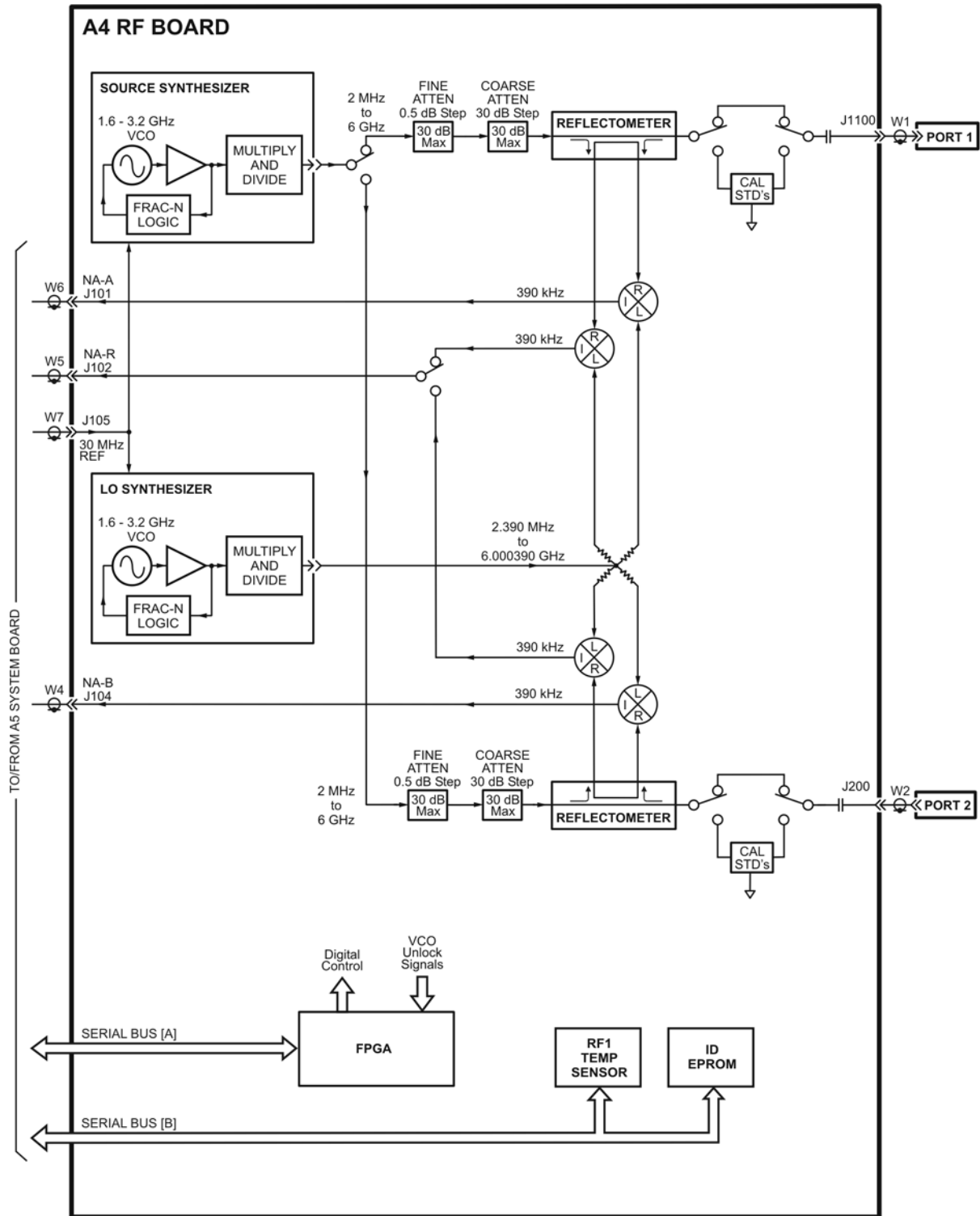

n9923a_rf_blk
11 November 2009

The settings of the FINE ATTEN and COARSE ATTEN attenuators between the source and the reflectometer are determined by the Hi/Lo power setting on the user interface.

Each reflectometer performs three functions:

- It passes the source output signal to either PORT 1 or PORT 2.
- It samples the source output to either PORT 1 or PORT 2.
- It samples the incoming signal at either PORT 1 or PORT 2.

The sampled signals are mixed with the LO signal to produce two 390 kHz IF signals, NA-A and NA-B.

The reflectometer dissipates up to 1.5 watts when active.

PORT 1 and PORT 2 each has a DC isolation capacitor (0.056uF).

Power Management Circuitry

The circuitry on the A4 RF board has five special sections that may be powered down for the purpose of power management. These sections may be selectively powered down (via “load switching”) when not required for the current operating mode of the analyzer.

The sections that may be selectively powered down are:

- Source—most of the source synthesizer circuitry
- LO—most of the LO synthesizer circuitry
- Reflectometer—put into a low power state

The load switching for the Source, and LO sections is accomplished on the A5 system board via the Analog Power Supply Load Switching circuitry.

The load switching for the Reflectometer and High-Band Preamp is accomplished on the A4 RF board.

Other Circuitry

The FPGA (Field Programmable Gate Array) communicates with the FPGA on the A5 system board via Serial Bus [A]. It provides the digital control for the functions on the A4 RF board. It also reads the VCO unlock signals.

Serial Bus [B] allows the System Monitor on the A5 system board to read a temperature sensor and the ID EPROM for the A4 RF board.

RF1 temperature sensor on the side of the A4 RF board that is away from the A5 system board. It is located near the edge of the A4 RF board that is farthest from the Port 1 and Port 2 connectors.

A5 System Board

The A5 system board controls all of the functions of the analyzer and digitizes the RF IF signals (NA-R, NA-A, and NA-B) from the A4 RF board.

The A6 SOM (System on Module) board is mounted directly on the A5 system board.

All external connections for the analyzer come through the A5 system board except for the PORT 2 and PORT 1 ports.

The A5 system board also controls the power switching and power management.

The instrument model number and serial number are stored on the A5 system board.

System Monitor (SM) Microcontroller

This is the heart of the analyzer. It is active whenever there is DC power available. The microcontroller has ultra-low power dissipation. It is sometimes referred to as the “MSP 430”.

The following is a list of some of the functions performed by the SM.

- It monitors the On/Off button on the front panel and responds appropriately.
- It controls the on/off functions of the various power supplies in the analyzer.
- It drives the On/Off button LED.
- It reads battery pack information via the Smart Batt Bus.
- It communicates with the battery charger IC via the Smart Batt Bus.
- It interfaces to the Battery Charger and Manager circuit.
- It interfaces to the Serial Bus [B] for communication with the temperature sensor and ID EPROM's on the printed circuit boards.
- It communicates to the A6 SOM board CPU via a serial port, UART.
- It stores the instrument model number and serial number.

Battery Charger and Manager

This circuitry controls charging of the battery based on a battery charger IC. This IC is powered by a digital output on the System Monitor. The System Monitor has the capability to reset the IC, if required, by recycling the power to the IC.

This circuitry also controls the source of the Unreg DC: Batt or Ext DC. It reads the battery pack information via the Smart Batt Bus. Batt Neg is connected to the A5 ground plane.

There is an input inrush current control circuit on the Ext DC input that limits inrush current to 4 amps.

Analog Power Supplies and Load Switching

Seven different analog supply voltages are generated from the Unreg DC. All of these are used on the A4 RF board and some are used on the A5 system board.

Some sections of the circuitry on the A4 RF board may be switched to low power modes to

conserve power and minimize heat. This is accomplished through load switching. See “Power Management Circuitry” on page 5-9 for more information.

Figure 5-3 Simplified System Board Block Diagram

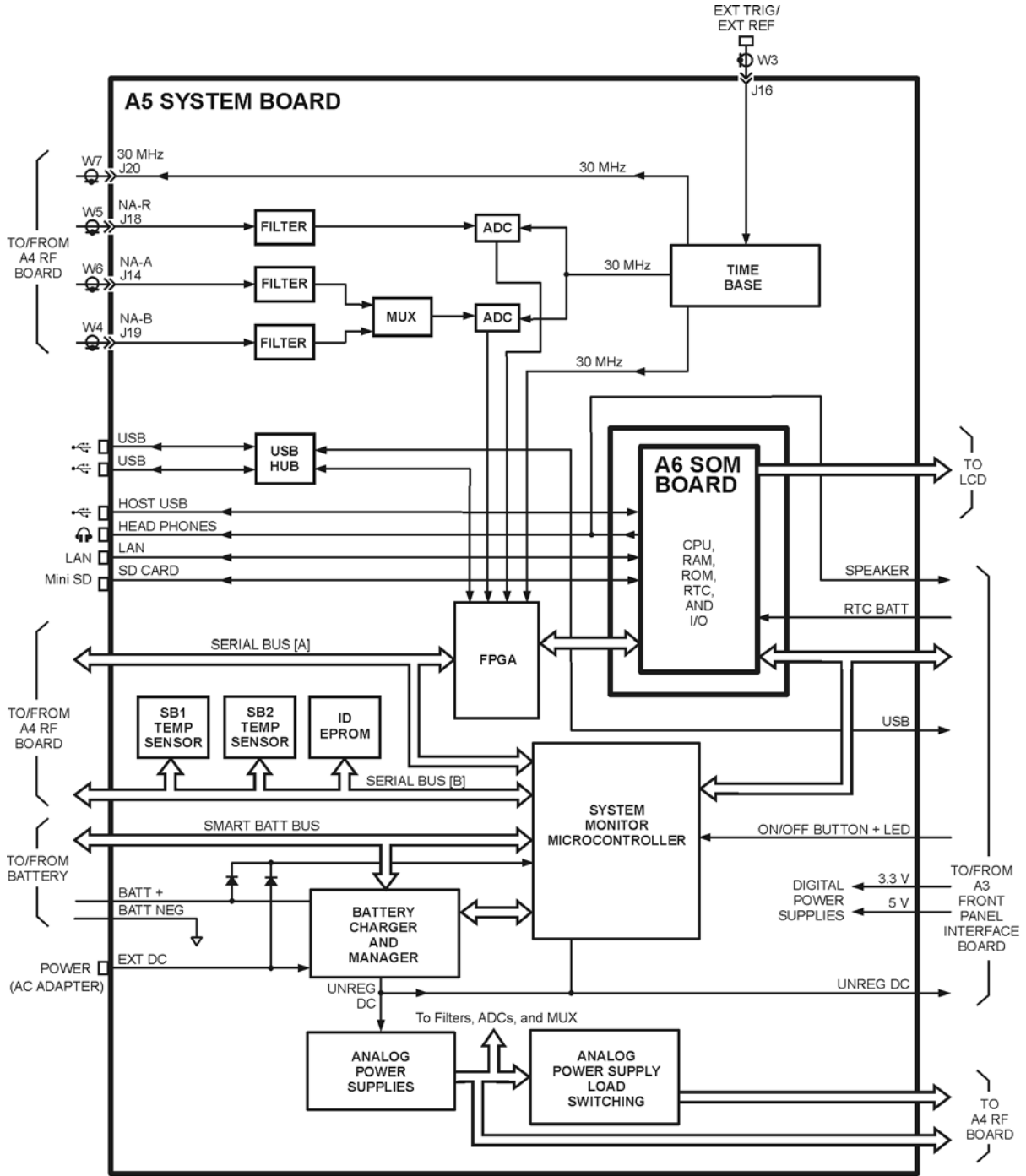

n9923a_system_blk
5 November 2009

The System Monitor controls the on/off functions of the analog power supplies. All are on or off together except for power sequencing.

This circuitry also monitors the Ext DC input and, if below 10.8 volts or above 21 volts, it disconnects this input from the Unreg DC.

There are two DC power supply lines: (1) Ext DC, and (2) Batt +. Each has a 5 amp fuse immediately after the connector on the printed circuit board.

FPGA

This FPGA:

- provides the interface between the A6 SOM board and the ADC,
- provides miscellaneous interfaces for circuitry on the A4 RF board, and
- communicates with the CPU via the USB interface.

Time Base

The Time Base is an internal TCXO that produces 30 MHz signals for use throughout the analyzer.

A 10 MHz signal at the EXT TRIG/EXT REF input may be used to provide an external time base. The external time base function is controlled via the user interface. Refer to the “External Frequency Reference” section of the *N9923A FieldFox RF Vector Network Analyzer User’s Guide* (Part Number N9923-90001) for additional information.

There is no external trigger (EXT TRIG) function at the time of this printing.

Filters, MUX, and ADC’s

The three Filters filter the IF signals in preparation for the ADC. Filter characteristics are fixed (not programmable).

The ADC’s digitize each of the IF signals received from the A4 RF board. The input to one of the ADC’s is multiplexed between the NA-A and NA-B input signals.

The 14-bit ADC’s sample at a rate of 30 mega samples per second.

Each ADC may be put into a low power mode when not active.

Temperature Sensors

The SB1 Temp Sensor is located on the A4 RF board side of the A5 system board near the headphone jack (J3).

The SB2 Temp Sensor is on the A4 RF board side of the A5 system board near the edge of the board against the battery compartment. This temperature sensor is not under a shield.

Audio Output Jack

When headphones are plugged into the audio output jack, the internal speaker is disabled.

LAN Connector

The LAN connector supports the LAN interface on the A6 SOM board. See [“LAN Interface” on page 5-25](#) for more details.

SOM Connector

Refer to [“A6 SOM Board” on page 5-13](#) for information on SOM (System on Module) functions.

A6 SOM Board

The A6 SOM (System on Module) board plugs directly into the A5 system board as a daughter board and contains:

- the CPU,
- 64 MB of flash ROM,
- 128 MB of RAM,
- real time clock, and
- I/O interface.

The interfaces on the SOM are:

- UART to the System Monitor on the A5 system board
- LCD interface
- Left and right audio outputs
- SD card bus
- USB host interface
- Interface to USB hub
- LAN interface 10/100 base T
- General purpose interface lines

The A6 SOM board is powered by the 3.3 volt digital supply.

Licenses which enable instrument options are stored in the A6 SOM flash ROM.

Main Battery

The battery is a rechargeable 10.8 V lithium-ion type. Refer to [“Battery Disposal” on page 1-7](#) for important information about replacing and disposing of this battery.

Refer to [“Battery Related Information” on page 5-16](#) for details on the main battery.

Grounding and Power

Grounding

Each printed circuit board has a single ground plane. The ground planes on the A4 RF board and A5 system board are connected via the common shields at multiple points. The ground plane on the A3 front panel interface board is connected to the ground plane on the A5 system board.

There are no separate grounds in the analyzer. There is no “star” ground point in the analyzer.

Batt Neg and Ext DC neg are connected to the A5 system board ground plane.

The A2 LCD assembly has two separate grounding circuits: the LCD power and control circuits and the backlight LED’s.

- The LCD power and control circuits share a ground that is connected to the ground plane on the A5 system board.
- The ground for the backlight LED’s is connected to the ground plane on the A3 front panel interface board.

Voltages and Power Supplies

The following power supplies exist within the analyzer:

- Digital 5 volts—generated from Unreg DC on the A3 front panel interface board, controlled by the System Monitor on the A5 system board, and used on the A3, A4, and A5 boards.
- Digital 3.3 volts—generated from Unreg DC on the A3 front panel interface board, on/off functions controlled by the System Monitor on the A5 system board, and used on the A2 LCD assembly and A3, A4, A5, and A6 boards.
- Analog supply voltages—seven separate voltages generated from Unreg DC on the A5 system board, on/off functions controlled by the System Monitor on the A5 system board.
- LCD backlight voltage—generated on the A3 front panel interface board from the digital 5 volt supply voltage.
- Power for the System Monitor circuit—3.3 volt circuit powered from Ext DC or Batt +, whichever is greater. Used on A5 system board only.
- Unreg DC—from Ext DC or Batt +, 21 volts max.
- Ext DC—from external Power AC Adapter, nominal 15 volts, acceptable up to 19 volts.
- Batt + —from main battery, nominal 12 volts.

All voltages except Ext DC, Batt +, and the System Monitor power can be turned on/off within the analyzer. Refer to [“Power Management Circuitry” on page 5-9](#) for more information.

Power Control and Management

Power States

The On/Off Button is used to switch between On, Off, and Standby power states:

Off Only the System Monitor and battery control circuits are powered up (if power is available from the battery or external power).

If the battery is charging, the LED below the On/Off Button slowly flashes orange with increasing intensity, otherwise this LED is off.

Some battery power is required in the “Off” state. A fully charged battery will discharge completely in four to six weeks when left in the analyzer.

On This is normal operation. The On/Off Button LED is steadily lit green.

Standby Only the digital power supplies are on. The CPU is in a low power state, maintaining RAM content. The On/Off Button LED flashes yellow briefly every two seconds.

During normal operation, unexpectedly disconnecting power to the analyzer (such as removing the main battery when the analyzer is not connected to external power) should not cause any problems. Simply re-apply power. No firmware problems are expected. Of course, this does not apply during a firmware upgrade.

Smart Power Management

The analyzer uses extensive “load switching” to minimize power dissipation. This is termed Smart Power Management (SPM). There are two motivations for power management:

- to extend battery run time
- to prevent overheating.

Sections of the circuitry are selectively powered down via “load switching”, depending on the operating mode of the analyzer. Five different sections of the circuitry on the A4 RF board may be controlled via “load switching”. These sections are as follows:

- Sources—switched to low power state between sweeps during CAT or NA modes.
- LO—switched to low power state when data is not being taken by receivers.

On the A5 system board, each of the ADC’s may be individually switched to a low power mode when not active.

Load switching is generally transparent to the user. One obvious exception is the that the source turns off during “retrace” in the CAT and NA modes.

Battery Related Information

Battery Description and Operation

The main battery is an SBS (Smart Battery System) compliant pack of lithium ion cells.

Refer to “[Battery Disposal](#)” on page 1-7 for important information about replacing and disposing of this battery.

The nominal voltage of the battery is 10.8 volts and normally varies from 9 to 12 volts.

The battery has built-in sensors, a processor, and control circuitry. This is referred to as the Smart Battery circuitry.

The Smart Battery circuitry communicates battery condition and history information digitally via a digital Smart Batt Bus. The Smart Battery circuitry is read-only.

Both the battery charging circuit and the System Monitor read battery information over the Smart Batt Bus.

The battery temperature reported by the analyzer is based on a sensor inside the battery. Temperature information is available over the Smart Batt Bus. The thermistor connection (T) on the battery is not used.

The Smart Battery circuit may shut down the battery when the temperature is out of the acceptable range or when the battery charge is too low.

See the “Working with the Lithium-Ion Battery” section of the *N9923A FieldFox RF Vector Network Analyzer User’s Guide* (Part Number N9923-90001) for additional information on:

- built in charge level gauge
- the battery information screen
- battery care

Battery Information Screen

Refer to the *N9923A FieldFox RF Vector Network Analyzer User’s Guide* (Part Number N9923-90001) for information on how to access this screen.

Most of the items displayed on the screen come directly from the battery via the Smart Batt Bus. Only the first three items are influenced by the analyzer.

Battery Charging Management

The battery pack determines when the battery needs charging and requests a charge over the Smart Batt Bus.

The Battery Charger and Manager circuit on the A5 system board responds by charging the battery if there is sufficient voltage on the Ext DC line. A minimum of approximately 15 volts is required to charge the battery.

The System Monitor on the A5 system board monitors the battery’s temperature and, if too high or too low, disables charging of the battery.

How to tell if the battery is charging:

- If the analyzer is On, the lightening bolt is displayed in the battery icon.

- If the analyzer is Off, the LED below the On/Off Button slowly flashes orange with increasing intensity.
- If the analyzer is in Standby, turn the analyzer on and observe the battery icon.

The battery charges much faster up to 70% of its full charge than it does above 70% of full charge.

Battery Life

When a battery is new, an instrument should operate for about four hours on a fully charged battery. The actual time will depend on operating mode and temperature.

As a battery goes through charge/discharge cycles, its capacity will decrease. A typical battery will have more than 70% of its initial capacity after 200 full discharge cycles when operating at 20 to 30 °C ambient temperature.

Operation in Modes

The *N9923A FieldFox RF Vector Network Analyzer User's Guide* (Part Number N9923-90001) describes the various modes of operation and describes the user interface for each mode. The following information describes how the hardware is used in the various modes to make measurements.

There are four basic modes of operation:

- CAT—Cable and Antenna Test
- NA—Network Analyzer
- VVM—Vector Voltmeter
- PM—Power Meter

CAT, NA, and VVM modes make similar measurements but are separate modes of operation.

Additional modes of operation may be created as new firmware is developed. The four basic modes listed above represent how the hardware may be used to make basic measurements. Additional modes will provide customized user interfaces but will not change how the basic measurements are performed.

The following table indicates port functionality for each mode of operation and the required options. See “[Service Related User Operations](#)” in [Chapter 8](#) for details.

Table 5-1. Port Function by Mode

Measurement Mode	PORT 1 Port	PORT 2 Port	Required Option(s)
CAT (Return Loss)	Input/Output	Inactive	305
CAT Insertion Loss	Output	Input	305
NA S11	Input/Output	Inactive	None (standard)
NA S12	Input	Output	122
NA S21	Output	Input	None (standard)
NA S22	Inactive	Input/Output	122
VVM 1-Port	Input/Output	Inactive	308
VVM 2-Port	Output	Input	308
Power Meter	Inactive	Inactive	302

For a given mode, the analyzer “remembers” the most recent state of the current mode when you change to another mode.

For most screens under System 7 key, the current measurement mode continues to operate while the screen is displayed. For instance, while the battery information screen is displayed, the measurement mode remains active.

There are two exceptions to this:

- the “Options (Licensing)” screen
- “Error Log” screen

When either of these screens is displayed, the firmware is in a special monitor mode and measurements are suspended.

CAT, NA, and VMM Modes

CAT, NA, and VMM modes make similar measurements (listed below) but are separate operating modes.

- Return Loss = S11 magnitude
- Insertion Loss = S21 magnitude

Unlike S11 and S21, the values displayed below zero for Return Loss and Insertion Loss are not negative.

There is no user control of the power level directly out of the source synthesizer on the A4 RF board.

The only user control of output power level is the high/low setting, 45 dB in or out.

Measurements in VMM mode are made at a single frequency.

Power Meter Mode

All measurement circuitry is switched to the low power state during PM (power meter) mode. This is the mode with the lowest power dissipation.

The analyzer has no power output capability in this mode. The analyzer essentially functions as a display for a USB power sensor.

Temperature Related Information

Four temperature sensors are in the analyzer: one on the A4 RF board, two on the A5 system board, and one in the battery pack.

- RF1—on the A4 RF board
- SB1—on the A5 system board near the headphone jack
- SB2—on the A5 system board near the battery compartment
- Battery pack—inside the battery pack

The battery pack has its own internal temperature sensor. The battery pack will shut itself down in the case of extreme temperatures.

See [Chapter 8](#) for instructions on viewing temperature readings.

See the *N9923A FieldFox RF Vector Network Analyzer User's Guide* (Part Number N9923-90001), “FieldFox High-Temperature Protection” section, for information about operation at high temperature.

The internal temperature of the unit is critical when executing the TME based software for tests and adjustments. See the TME help for detailed information.

Under typical bench top (indoor) conditions, the internal temperature of the unit will be about 20 °C above ambient once the internal temperature has stabilized. It will typically take 60 to 90 minutes for the internal temperature to stabilize when a “cold” unit is turned on.

User Calibration in CAT and NA Modes

There are two types of calibrations for the CAT and NA modes: one port and two port. See the *N9923A FieldFox RF Vector Network Analyzer User's Guide* (Part number N9923-90001) "Calibration for CAT and NA Modes" section for specific instructions for performing these calibrations. A calibration performed in CAT mode will be applied in NA mode and vice versa.

When a user calibration is performed, the full frequency range of the analyzer is calibrated even though the current state of the analyzer may be less than the full range. This allows a calibration to be "interpolated" beyond the frequencies set at the time of calibration (an asterisk "*" on the display indicates interpolation).

Do not leave cal standards connected to the PORT 2 or PORT 1 ports for more than three minutes. Heat in the port connectors may affect the accuracy of the standards.

Table 5-2. Cal Status Indicators

Indicator	Meaning	Additional Indicators
CalRdy	Preset (factory) calibration is active	* = interpolation active ? = Measurement conditions have changed.
Cal ON Q	QuickCal calibration is active	* = interpolation active ? = Measurement conditions have changed.
Cal ON U	User calibration is active	* = interpolation active ? = Measurement conditions have changed.
Cal OFF	Calibration is inactive	
Cal OFF*	No calibration available to activate for this measurement.	

Factory Calibration

When the analyzer is adjusted at the factory or during annual calibration, a preset calibration is stored in the analyzer (CalReady).

The preset calibration covers the full frequency range of the analyzer. The preset calibration is active whenever "CalRdy" is displayed on the left side of the screen. Presetting the analyzer activates the preset calibration.

The preset calibration provides very good measurement performance at the PORT 1 and Port 2 connectors when the analyzer has thermally stabilized to room temperature.

The preset calibration should be re-characterized every 12 months to maintain accuracy. This is accomplished via the Error Terms adjustment in the TME. Refer to [Chapter 3](#).

QuickCal

The QuickCal function mathematically "extends" the preset calibration to the end of a cable or adapter. It is a firmware only function; it does not involve analyzer hardware.

User Calibration

A user calibration is performed with a mechanical cal kit. The N9923A User's Guide (Part Number N9923-90001) refers to a user calibration as a "mechanical cal".

Firmware Related Information

General Description

The analyzer is based on the Windows CE¹ operating system. This is a closed system; no direct user access to the desktop of general operating system functions is provided.

The file system for Windows CE is maintained in flash memory on the A6 SOM board. There is limited access to the file system. Most memory is in protected region and not directly accessible by the user.

The user accessible memory is under UserData. See the “File Management” section of the *N9923A FieldFox RF Vector Network Analyzer User’s Guide* (Part Number N9923-90001) for instructions on saving, recalling, and managing files in the unprotected memory.

User Accessible Files

- Directory structure below UserData in the A6 SOM board flash memory (approximately 20 MB).
- External USB flash memory plugged in the analyzer.
- External SD memory card plugged into the analyzer.

NOTE: When copying files, a “Copy_....” directory is created at the root of the destination device as the destination for the copied file(s). This characteristic generally makes it impossible to copy a file into the desired directory under UserData in the A6 SOM board flash memory. This limits the usefulness of copying files to or within UserData.

Operational Files

- Results from adjustments performed under TME (see [Chapter 3](#))—not directly available to user.
- File resulting from CAT/NA user calibration—not directly available to user.
- Cal kit definition files—stored in UserData\calkits.
- Cable definition files—stored in UserData\Cables.
- Error log—not directly available to user. See “[Error Log](#)” further on in this section for accessing error log information.

Erase User Data Utility

A utility to erase all directories and files in the UserData directory is available. After the flash memory is erased, the boot process returns the UserData directories and files to the state as shipped from the factory. The System Information screen indicates the time and date of the most recent erase.

See [Chapter 8](#) for instructions on executing the Erase User data utility.

1. Windows® and Windows CE® are U.S. registered trademarks of Microsoft Corporation.

Error Log

See [Chapter 8](#) for instructions on viewing the error log.

The error log is cleared each time the analyzer is powered off.

Generally, an entry in the error log is created whenever an error message is displayed.

EXAMPLE: Attempting to set the frequency to a value of “.” (a decimal point), will generate an entry in the error log.

Firmware Upgrades

Firmware upgrades are available on the Internet. Refer to instructions in the “Update FieldFox Firmware” section of the *N9923A FieldFox RF Vector Network Analyzer User’s Guide* (Part Number N9923-90001) for details.

See [Chapter 8](#) for instructions on viewing the current firmware revision.

The following information will be included in the display.

- Firmware Release = FieldFox application firmware revision
- FPGA Rev = code revision for FPGA
- SBM Boot Rev = revision of boot code for System Microcontroller
- SBM Main Rev = revision of main code for System Microcontroller

A firmware upgrade includes three sections:

- the FieldFox application firmware and the Windows CE operation system on the A6 SOM board.
- the firmware in the System Monitor Microcontroller on the A5 system board.
- the FPGA code on the A5 system board.

The System Monitor firmware update and the FPGA code update are executed only if not up-to-date.

It is important to maintain power to the analyzer during the update process.

After unplugging the USB flash memory stick during the firmware upgrade process, wait for the analyzer to activate the CAT mode before operating the analyzer.

LAN Interface

See the “System Configuration” section of the *N9923A FieldFox RF Vector Network Analyzer User’s Guide* (Part Number N9923-90001) for details on reviewing and configuring LAN settings.

The LAN interface supports Auto MDIX. When a LAN cable is connected to the FieldFox, if the other end of the cable supports Auto MDIX, there is no need for a cross-over cable.

There are two LEDs on the LAN connector. When there is successful communication over a LAN cable, both LEDs are active. If both LEDs are not active, consider using a cross-over cable.

6 Replaceable Parts

Information in This Chapter

This chapter:

- identifies the replaceable parts for the N9923A RF vector network analyzer.
- includes several tables and illustrations to assist you in identifying the correct part for your analyzer.
- contains ordering information for new assemblies and rebuilt-exchange assemblies.

Chapter Six at-a-Glance

Section Title	Summary of Content	Start Page
Ordering Information	How to order a replaceable part from Agilent Technologies.	Page 6-3
Assembly Replacement Procedure	The correct sequence for determining the failure of and replacing a defective assembly.	Page 6-4
Replaceable Parts Listings	Tables with illustrations that list all replaceable parts in your analyzer:	Page 6-5

Ordering Information

To order a part listed in the replaceable parts lists:

- include the part number
- indicate the quantity required
- Contact Agilent Technologies for instructions on where to send the order. Refer to [“Contacting Agilent” on page 2-6](#).

To order a part that is not listed in the replaceable parts lists:

- include the instrument model number and complete instrument serial number
- include the description and function of the part
- indicate the quantity required
- Contact Agilent Technologies for instructions on where to send the order. Refer to [“Contacting Agilent” on page 2-6](#).

Assembly Replacement Procedure

The following steps describe how to replace an assembly in the analyzer.

- Step 1.** Identify the faulty group. Begin with [Chapter 4, “Troubleshooting.”](#) Follow up with the appropriate troubleshooting chapter that identifies the faulty assembly.
- Step 2.** Order a replacement assembly. Refer to this chapter for part numbers and ordering information.
- Step 3.** Replace the faulty assembly and determine what adjustments and performance tests are necessary. Refer to [Chapter 7, “Repair and Replacement Procedures.”](#)
- Step 4.** Perform the necessary adjustments. Refer to [Chapter 3, “Tests and Adjustments.”](#)
- Step 5.** Perform the necessary performance tests. Refer to [Chapter 3, “Tests and Adjustments.”](#)

Replaceable Parts Listings

Entire Analyzer

Figure 6-1 Entire Analyzer, Exploded View

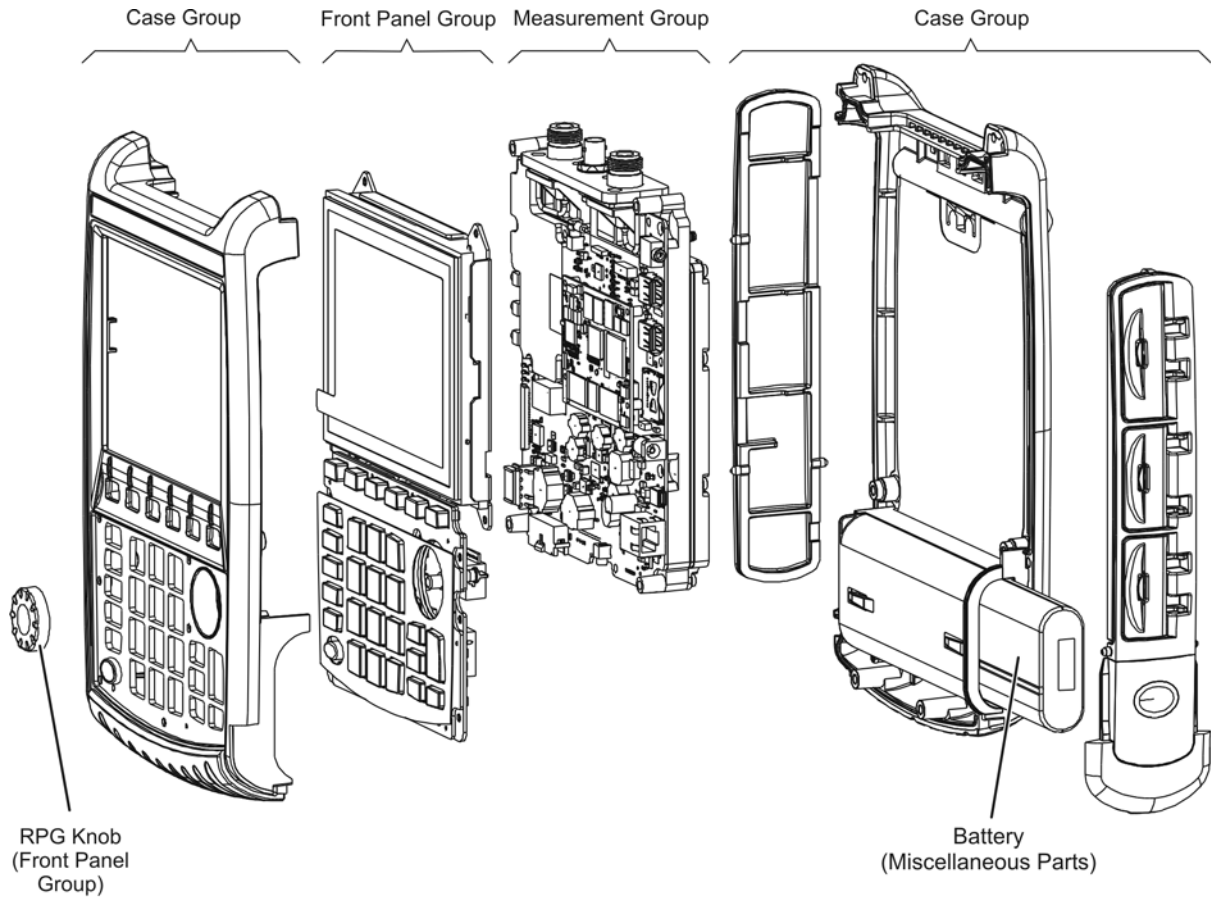

n9912_90003_601

Descriptions and part numbers for the assemblies and parts in each group shown in the above illustration can be found at the following locations:

- “Front Panel Group” on page 6-6
- “Measurement Group” on page 6-8
- “Case Group” on page 6-10

Miscellaneous parts and accessories not illustrated in any of these groups are listed under:

- “Miscellaneous Parts” on page 6-12

Front Panel Group¹

Reference Designator	Part Number	Qty	Description
Replacement Assemblies			
A3 Front Panel Board Assembly	N9923-60003	1	Front Panel Board Assembly —Includes: A3 front panel interface board
Separately Replaceable Individual Parts and Assemblies			
A1	Keypad assembly (Part of Front Enclosure Assembly and not separately replaceable; see “ Case Group ” on page 6-10.)		
A2	2090-0968	1	LCD assembly, 6.5-inch TFT VGA
(1)	LCD lens filter (Part of Front Enclosure Assembly and not separately replaceable; see “ Case Group ” on page 6-10.)		
(2)	N9912-00001	1	LCD shield (bracket)
(3)	0515-1521	13	Screw, machine, 90-deg flat head, M3.0 x 5 mm
(4)	1990-3613	1	RPG (Rotary Pulse Generator). Includes cable W12, nut, and washer.
(5)	W1312-40066	1	RPG knob
(6)	N9912-60017	1	Cable W13, A2 LCD to A3 front panel interface board
(7)	N9912-60006	1	Cable W14, ribbon, A3 front panel interface board to A5 system board
(8)	N9912-60016	1	Cable W11, A2 LCD to A5 system board
(9)	N9912-20035	1	Gap pad, LCD shield
(10)	N9912-20038	1	Gap pad, LCD shield
(11)	1420-0536	1	Battery, Lithium-ion, 3V (For Real Time Clock (RTC) backup.)

1. Each time the N9923A case is opened for any reason, you must order a [Repair and Re-assembly Kit](#). See “[Miscellaneous Parts](#)” on page 6-12.

Figure 6-2 Front Panel Group, Exploded View

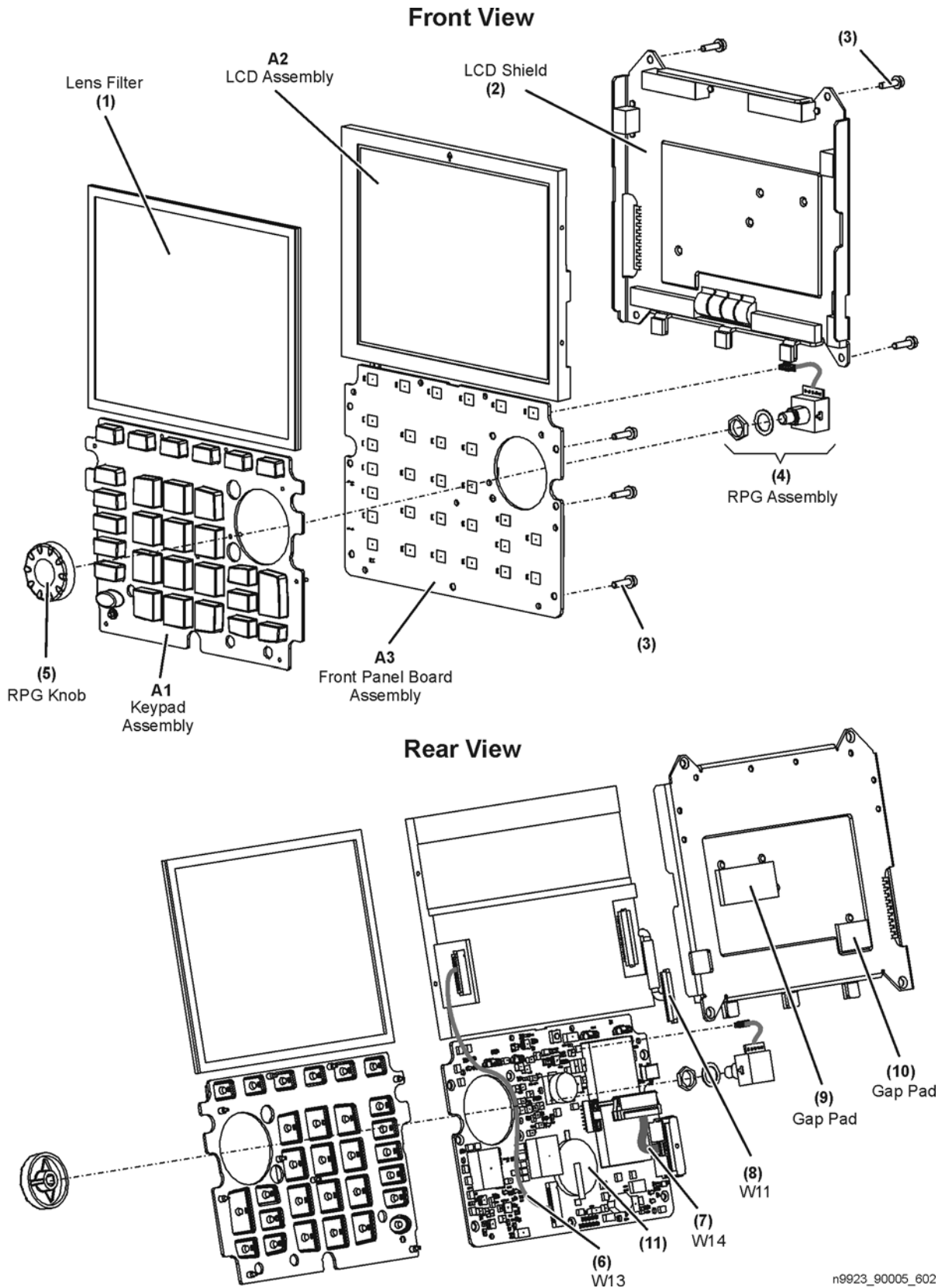

n9923_90005_602

Measurement Group¹

Reference Designator	Part Number	Qty	Description
Replacement Assemblies			
RF Assembly	N9923-60001	1	RF Assembly —Includes the following: A4 RF board; (1) system board gasket kit, 2 gaskets; (2) RFI wafer gasket, qty 2; (3) Insulator, qty 2; (4) Thread guard, big pocket; (5) Thread guard, medium pocket; (6) Thread guard, small pocket; (7) Polyiron, Port 1, reflectometer; (8) Polyiron, Port 2, reflectometer; (9) Polyiron, Port 1, output amp; (10) Polyiron, Port 2 output amp; (11) Shield, bottom, RF; (12) Shield, top, RF; (13) Cable W2, semi-rigid, PORT 2; (14) Cable W1, semi-rigid, PORT 1; (15) Gap pad, 6 mm square; (16) RFI O-ring, qty 2; (17) RFI strip, qty 4; (18) Adapter, coaxial, straight, female type-N to female 3.5 mm, qty 2; (19) Screw, machine w/crest cup washer, pan head, M3.0 x 12 mm, qty 25; (20) Screw, machine w/crest cup washer, pan head, M3.0 x 8 mm, qty 4.
System Board Assembly	N9923-60002	1	System Board Assembly —Includes the following: A5 system board; (1) System gasket kit assembly, 2 gaskets; (21) Clamp, stick-on, qty 2.
Coax Cable Assembly	N9912-60029	1	Coax Cable Assembly —Includes the following: (22) Cables W4 and W6, RF, flexible, qty 2; (23) Spiral wrap, plastic.
RF Top Panel Assembly	N9923-60021	1	RF Top Panel Assembly —Includes the following: (24) Panel, RF, die-cast; (25) Connector cover (tethered cap), for type-N connector, qty 2; (26) Overlay, RF; (27) Gasket, RF; (30) Cable W3, RF coax with BNC connector, EXT TRIG/EXT REF connector; (31) Washer, internal tooth, 15/32-inch; (32) Nut, specialty, 15/32-inch–32 thread.
Separately Replaceable Individual Parts and Assemblies			
A6	1150-8023	1	SOM Board , 532 MHz processor, 128 MB-SDRAM
(1)	N9923-60019	1	System board gasket kit, 2 gaskets for A5 system board
(3)	N9912-20033	2	Insulator, w/pad
(13)	N9923-20013	1	Cable W2, semi-rigid, PORT 2
(14)	N9923-20012	1	Cable W1, semi-rigid, PORT 1
(16)	8160-0963	2	RFI O-ring
(18)	1250-2180	2	Adapter, coaxial, straight, female type-N to female 3.5 mm
(20)	0515-0372	4	Screw, machine w/crest cup washer, pan head, M3.0 x 8 mm
(25)	W1312-40069	2	Connector cover (tethered cap), for type-N connector
(28)	N9912-20116	1	System board top shield
(29)	N9912-20028	1	Pad, A6 system board top shield to A2 LCD
(30)	8121-0964	1	Cable W3, RF coax with BNC connector, EXT TRIG/EXT REF connector
(31)	2190-0102	1	Washer, internal tooth, 15/32-inch
(32)	0590-1251	1	Nut, specialty, 15/32-inch - 32 thread
(33)	8121-1929	2	Cable W5 and W7, RF coax, flexible
(34)	0515-0374	4	Screw, machine w/crest cup washer, pan head, M3.0 x 10 mm
(35)	0515-0430	6	Screw, machine w/crest cup washer, pan head, M3.0 x 6 mm
(36)	0515-1940	4	Screw, machine w/patch lock, pan head, M2.5 x 6 mm
(37)	0515-2349	6	Screw, machine, 90-deg flat head, M3.0 x 14 mm

1. Each time the N9923A case is opened for any reason, you must order a [Repair and Re-assembly Kit](#). See “Miscellaneous Parts” on page 6-12.

Figure 6-3 Measurement Group, Exploded View

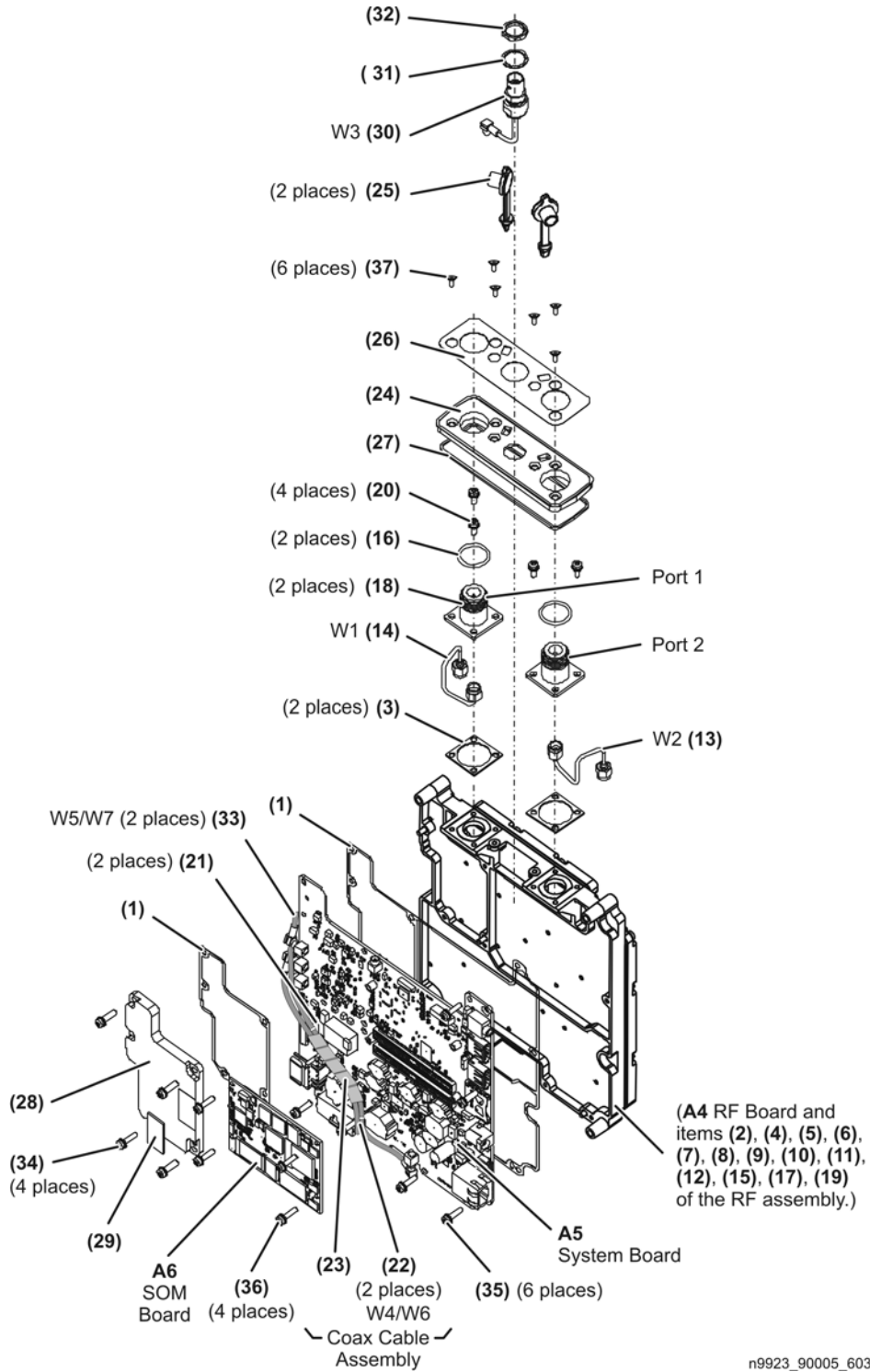

Case Group¹

Reference Designator	Part Number	Qty	Description
Replacement Assemblies			
Front Enclosure Assembly	N9923-60020	1	Front Enclosure Assembly —Includes the following: (1) Front case with A1 keypad installed (2) RFI O-strip, hollow (3) LCD lens filter (4) Keypad overlay (5) Model label, nameplate overlay, 4 GHz (5) Model label, nameplate overlay, 6 GHz
Rear Enclosure Assembly	N9912-60022	1	Rear Enclosure Assembly —Includes the following: (6) Rear case (7) RF gap pad (8) Rear panel overlay
I/O Panel Assembly	N9923-60023	1	I/O Panel Assembly —Includes the following: (9) System board connector panel (I/O side panel) (10) Overlay, I/O panel top (USB) (11) Overlay, I/O panel middle (SD) (12) Overlay, I/O panel bottom (LAN)
Kick Stand Assembly	N9912-60028	1	Kick Stand Assembly —Includes the following: (13) Kickstand (14) Friction hinge (15) Screw (for hinge), qty 4 (16) Hinge cover (17) Screw (for hinge cover), qty 4
Separately Replaceable Individual Parts and Assemblies			
(4)	N9912-80005	1	Keypad overlay
(5)	N9923-80001	1	Model label, nameplate overlay, 4 GHz
	N9923-80006	1	Model label, nameplate overlay, 6 GHz
(14)	3110-0629	1	Friction hinge
(15)	0515-1940	4	Screw, machine w/patch lock, pan head, M2.5 x 6 mm
(16)	W1312-40068	1	Hinge cover
(17)	0515-5133	4	Screw, machine, button head, M3.0 x 8 mm
(18)	0515-5153	6	Screw, machine, w/flat washer, pan head, M3.0 x 35 mm
(19)	N9912-60007	1	Battery cable
(20)	W1312-40060	1	Battery door cover
(21)	N9912-40006	2	Hole plugs
(22)	0515-1521	2	Screw, machine, 90-deg flat head, M3.0 x 5 mm

1. Each time the N9923A case is opened for any reason, you must order a [Repair and Re-assembly Kit](#). See “Miscellaneous Parts” on page 6-12.

Reference Designator	Part Number	Qty	Description
(23)	N9910-80002	1	Strap handle
(24)	W1312-40056	1	Blank side panel
(25)	1480-0793	4	Dowel pins
(26)	W1312-60048	1	Door, top (USB)
(27)	W1312-60049	1	Door, middle (SD)
(28)	W1312-60050	1	Door, bottom (LAN)

Figure 6-4 Case Group, Exploded View

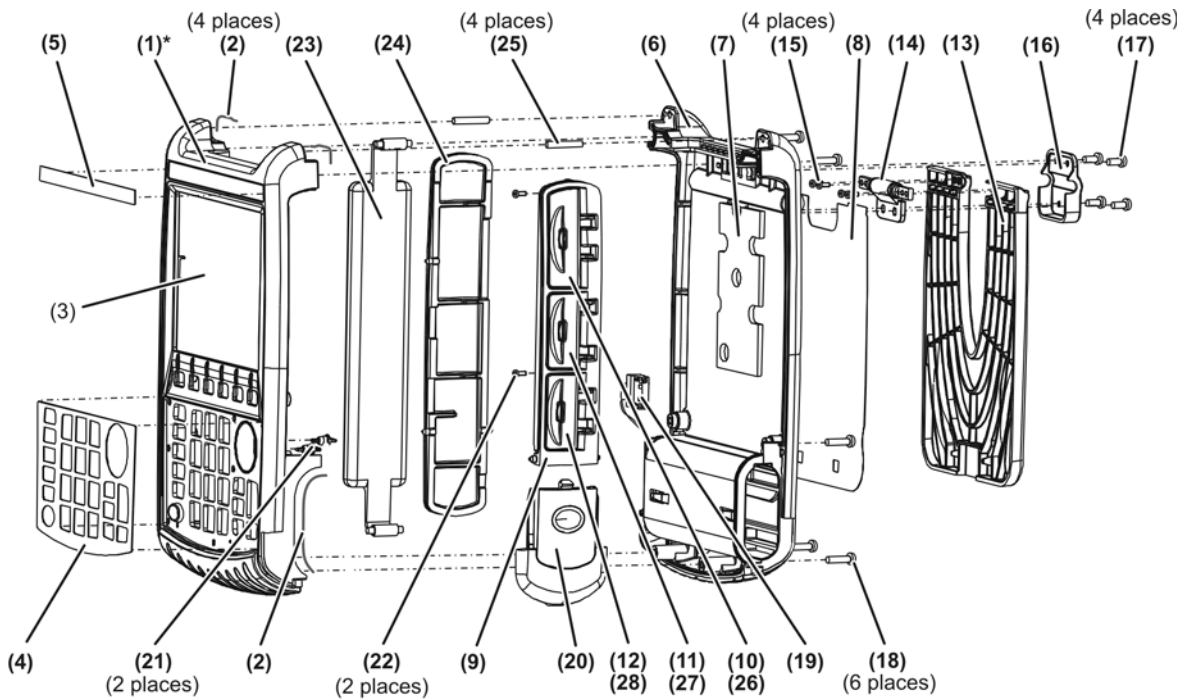

* The front case (1) comes with the A1 keypad installed.

n9923_90005_604

Miscellaneous Parts

Table 6-1 Part Numbers for Miscellaneous Parts and Accessories

Description	Model or Part Number
Repair and Re-assembly Kit	
IMPORTANT	
This kit is required each time the N9923A case is opened for any reason. The kit includes the following items, some or all of which are necessary to re-assemble the internal assemblies and the case, depending upon the depth of the repair.	
Repair and Re-assembly Kit (Includes the following items.)	N9912-60027
Gasket, for blank side panel (larger size); qty 1	N9912-40002
Gasket, for I/O side panel (smaller size); qty 1	N9912-40003
Screw, machine, w/flat washer, pan head, M3.0 x 35 mm; qty 6	0515-5153
Screw, machine, 90-deg flat head, M3.0 x 5 mm; qty 15	0515-1521
Screw, machine w/crest cup washer, pan head, M3.0 x 6 mm; qty 6	0515-0430
Screw, machine w/crest cup washer, pan head, M3.0 x 10 mm; qty 4	0515-0374
Screw, machine w/patch lock, pan head, M2.5 x 6 mm; qty 4	0515-1940
Screw, machine, 90-deg flat head, M3.0 x 14 mm; qty 6	0515-2349
Tape, 1/4-inch x 1-inch, for LCD ribbon cable; qty 3	N9912-20043
Service Tools	
T-8 TORX driver; set to 6 in-lb	N/A
T-10 TORX driver; set to 9 in-lb	N/A
5/16 inch, open-end torque wrench; set to 10 in-lb	N/A
7/16 inch, hex nut wrench or “nut driver”; set to 9 in-lb	N/A
9/16 inch, open-end torque wrench; set to 21 in-lb	N/A
Documentation	
User’s Guide	N9923-90001
Programming Guide	N9923-90003
Service Guide	N9923-90018
ESD Supplies	
Adjustable antistatic wrist strap	9300-1367
Antistatic wrist strap grounding cord (5 foot length)	9300-0980
Static control table mat and earth ground wire	9300-0797
ESD heel strap	9300-1126
Battery^a	
Lithium-ion, 10.8 V, rechargeable (LCD gauge)	1420-0891

a. Refer to “[Battery Disposal](#)” on page 1-7 for instructions on disposing of the old battery.

7 Repair and Replacement Procedures

Information in This Chapter

This chapter contains procedures for removing and replacing the major assemblies of your N9923A RF vector network analyzer.

Chapter Seven at-a-Glance

Section Title	Summary of Content	Start Page
Personal Safety Warnings	Warnings and cautions pertaining to personal safety.	Page 7-3
Electrostatic Discharge (ESD) Protection	Information pertaining to ESD protection.	Page 7-3
Assembly Replacement Sequence	A step-by-step procedure for how to identify the faulty assembly, replace it with a new one, and re-adjust your analyzer when done.	Page 7-4
Table of Removal and Replacement Procedures	A table of removal and replacement procedures and the corresponding page number where they are located.	Page 7-4
Removal and Replacement Procedures	The actual procedures for removing and replacing the major assemblies in your analyzer. <i>The procedures occur in assembly reference designator numerical order.</i>	See Table 7-1 on page 7-4 for specific procedures.
Post-Repair Procedures	A table of the proper tests, verifications, and adjustments to perform on your analyzer after repair.	Page 7-37

Personal Safety Warnings

WARNING **These servicing instructions are for use by qualified personnel only. To avoid electrical shock, do not perform any servicing unless you are qualified to do so.**

WARNING **Danger of explosion if battery is incorrectly replaced. Replace only with the same or equivalent type recommended. Discard used batteries according to manufacturer's instructions.**

Safety Earth Ground

WARNING **This is a Safety Class I product (provided with a protective earthing ground incorporated in the power cord). The mains plug shall only be inserted in a socket outlet provided with a protective earth contact. Any interruption of the protective conductor, inside or outside of the instrument, will make the instrument dangerous. Intentional interruption is prohibited.**

CAUTION Always use the three-prong AC power cord supplied with this product. Failure to ensure adequate grounding by not using this cord may cause product damage.

Electrostatic Discharge (ESD) Protection

CAUTION Many of the assemblies in this instrument are very susceptible to damage from electrostatic discharge (ESD). Perform the following procedures only at a static-safe workstation and wear a grounded wrist strap.

This is important. If not properly protected against, electrostatic discharge can seriously damage your analyzer, resulting in costly repair.

To reduce the chance of electrostatic discharge, follow all of the recommendations outlined in [“Electrostatic Discharge Protection” on page 1-5](#), for all of the procedures in this chapter.

Assembly Replacement Sequence

The following steps show the sequence that you should follow to replace an assembly in the network analyzer.

- Step 1.** Identify the faulty group. Begin with [Chapter 4, “Troubleshooting.”](#)
- Step 2.** Order a replacement assembly. Refer to [Chapter 6, “Replaceable Parts.”](#)
- Step 3.** Replace the faulty assembly and determine what adjustments are necessary. Refer to [“Post-Repair Procedures”](#) in this chapter.
- Step 4.** Perform the necessary adjustments. Refer to [Chapter 3, “Tests and Adjustments.”](#)
- Step 5.** Perform the necessary performance tests. Refer to [Chapter 3, “Tests and Adjustments.”](#)

Removal and Replacement Procedures

Table 7-1 List of Procedures

Reference Designator or Name	Assembly Description	Location
Case parts	All enclosure case parts	Page 7-6
RPG	RPG (part of front panel group)	Page 7-18
RPG knob	RPG knob (part of front panel group)	Page 7-18
RTC battery	Backup battery for real time clock (Soldered onto the A3 front panel interface board.)	Page 7-24
Main battery	Primary power battery	Page 7-5
A1	Keypad	Page 7-22
A2	LCD	Page 7-20
A3	Front panel interface board	Page 7-22
A4	RF board	Page 7-25
A5	System board	Page 7-25
A6	SOM board	Page 7-25

Removing and Replacing the Main Battery

Tools Required

- None

IMPORTANT Refer to [“Battery Disposal” on page 1-7](#) for important instructions on disposing of the old battery.

Replacing the Main Battery

1. Disconnect the power cord.
2. Remove the battery compartment door by pushing in on the detent and then sliding the door downwards.
3. Note the orientation of the battery for installation of the replacement.
4. Remove the old battery and install the new battery in the battery compartment.
5. Reinstall the battery compartment door by aligning it in position and then sliding it upwards until an audible click is heard.

Figure 7-1 Replacing the Main Battery

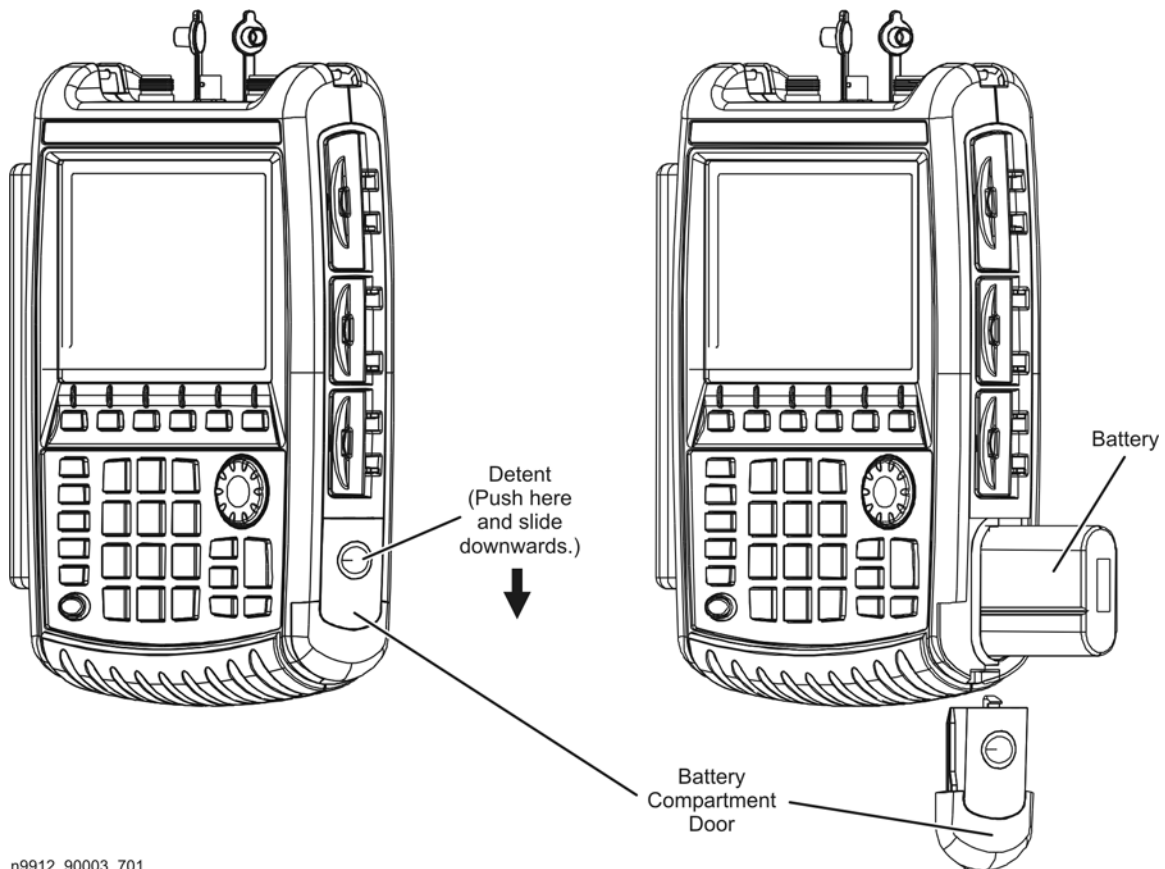

n9912_90003_701

Removing and Replacing the Case Group Parts

Tools Required

- T-8 TORX driver (set to 6 in-lb)
- T-10 TORX driver (set to 9 in-lb)
- Isopropyl alcohol (**Use only in a well ventilated area.**)
- [Repair and Re-assembly Kit](#). Refer to “Miscellaneous Parts” on page 6-12.

WARNING Before beginning any repair, disconnect the power cord.

Replacing the Kickstand, Hinge Cover, and Hinge

1. Remove, and discard, the four screws (item 1) from the kickstand hinge cover. New screws are provided in the [Repair and Re-assembly Kit](#).

Figure 7-2 Replacing the Kickstand and Hinge Cover

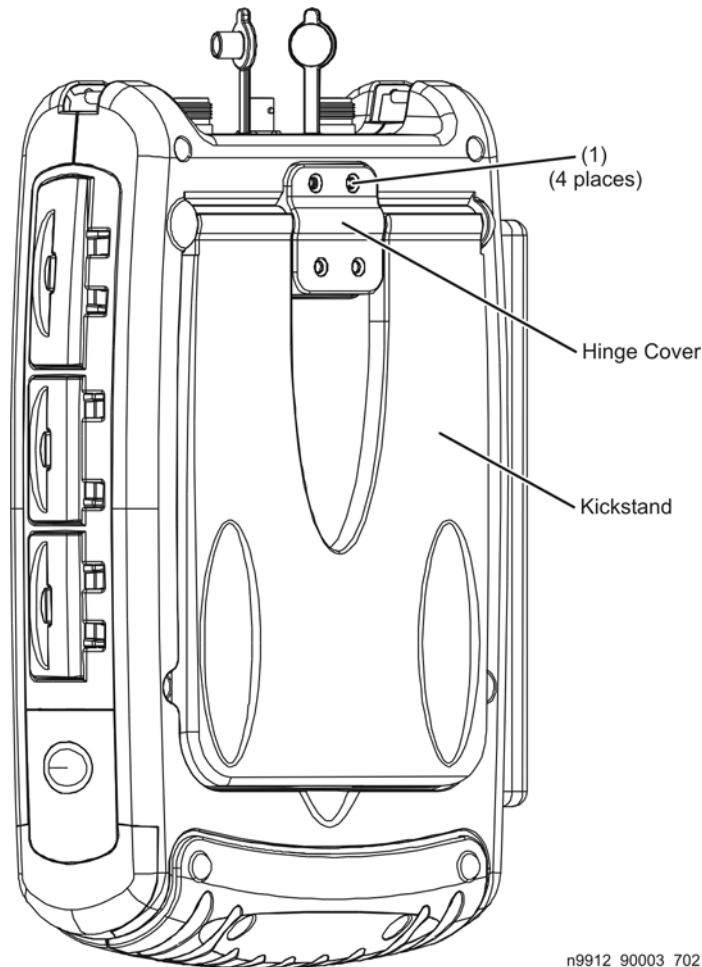

2. To replace the entire kickstand assembly:
 - a. Lift the kickstand assembly off of the rear case and discard it.
 - b. Place the new kickstand assembly on the rear case.
 - c. Place the new hinge cover in position and secure it with four new screws. A new hinge cover and new screws are provided in the [Repair and Re-assembly Kit](#).
3. To replace the hinge cover:
 - a. Position the new hinge cover in place and install four new screws. New screws are provided in the [Repair and Re-assembly Kit](#).
4. To replace the hinge:
 - a. Lift the kickstand assembly off of the rear case.
 - b. Remove and discard the four hinge attachment screws (item 2).
 - c. Place the new hinge in position and install with four new screws. New screws are provided in the [Repair and Re-assembly Kit](#).
 - d. Place the kickstand assembly in place on the rear case and reinstall the hinge cover with new screws provided in the [Repair and Re-assembly Kit](#).

Figure 7-3 Replacing the Hinge

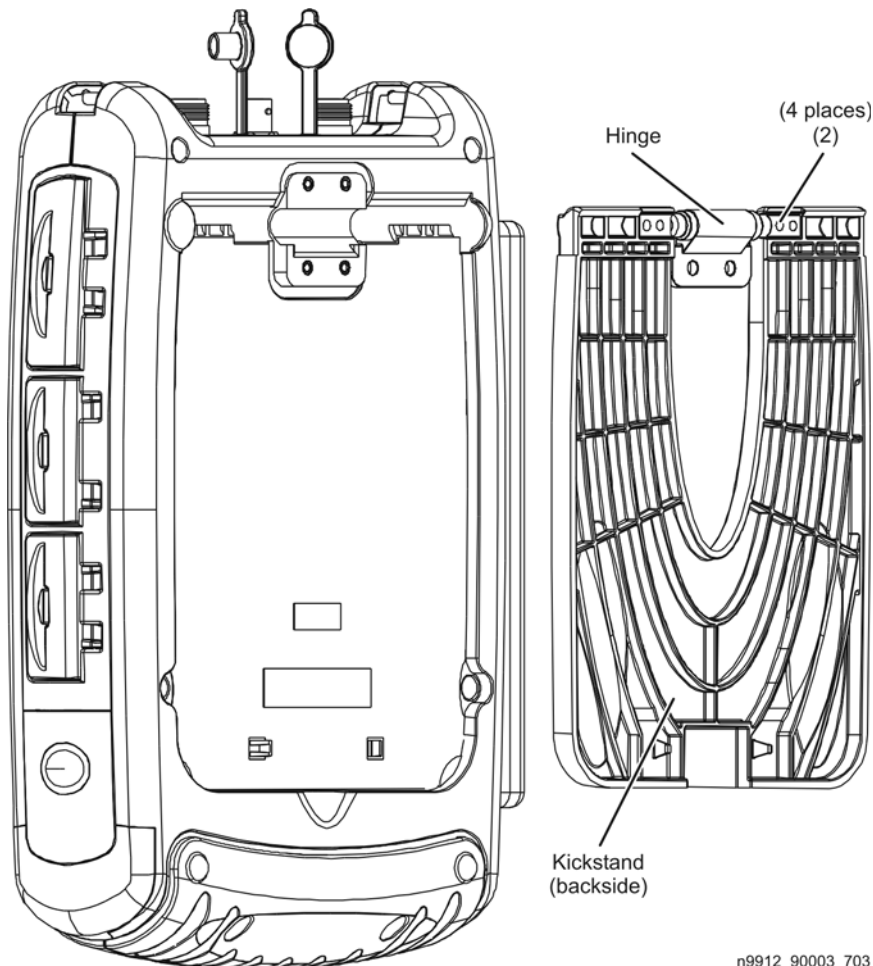

n9912_90003_703

Separating the Front and Rear Cases

1. Remove the battery. Refer to [“Removing and Replacing the Main Battery”](#) on page 7-5.
2. Loosen the six screws (item 3) that secure the RF top panel. It should not be necessary to remove these screws, just loosen them.
3. Remove, and discard, the six screws (item 4) that secure the rear case to the front case. New screws are provided in the [Repair and Re-assembly Kit](#).

Figure 7-4 Separating the Front and Rear Cases (1)

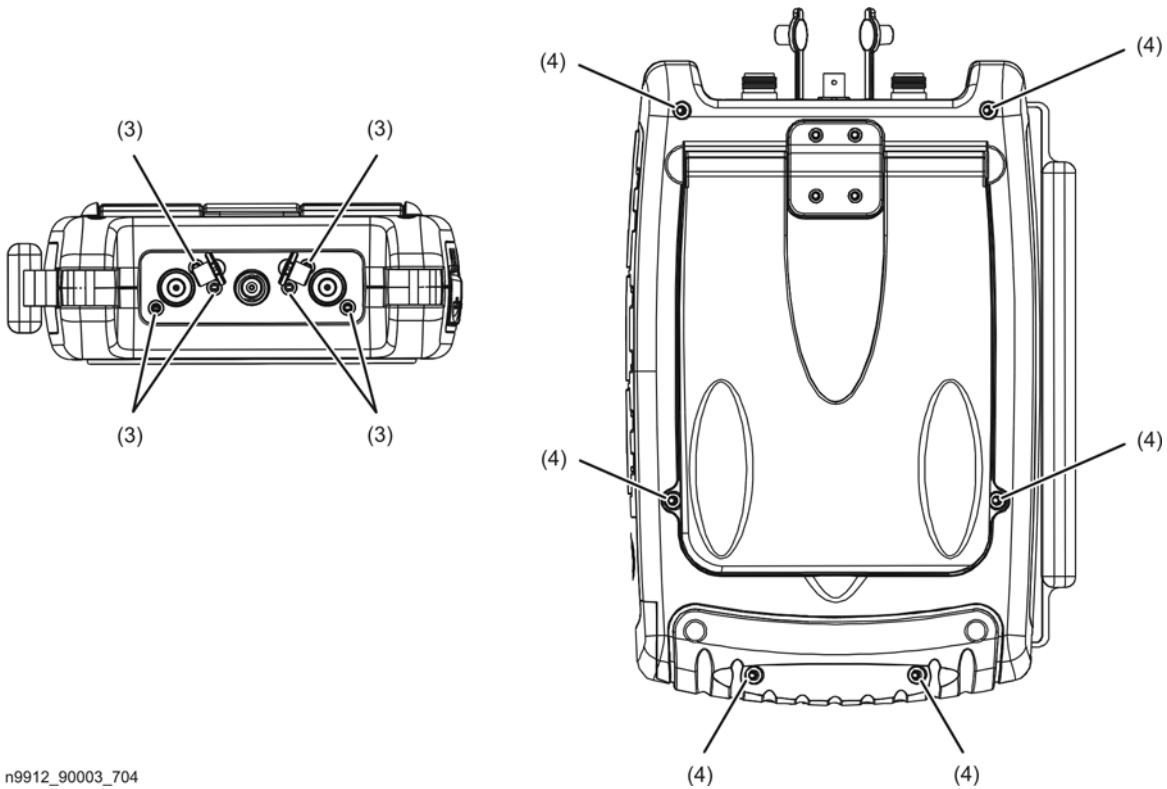

n9912_90003_704

4. Separate the cases and position the rear case to one side, as shown in [Figure 7-5](#), to allow access to the blank side panel and strap handle.
5. Remove the strap handle from the two dowel pins.
6. Remove the blank side panel from the groove in the front case.

Figure 7-5 Separating the Front and Rear Cases (2)

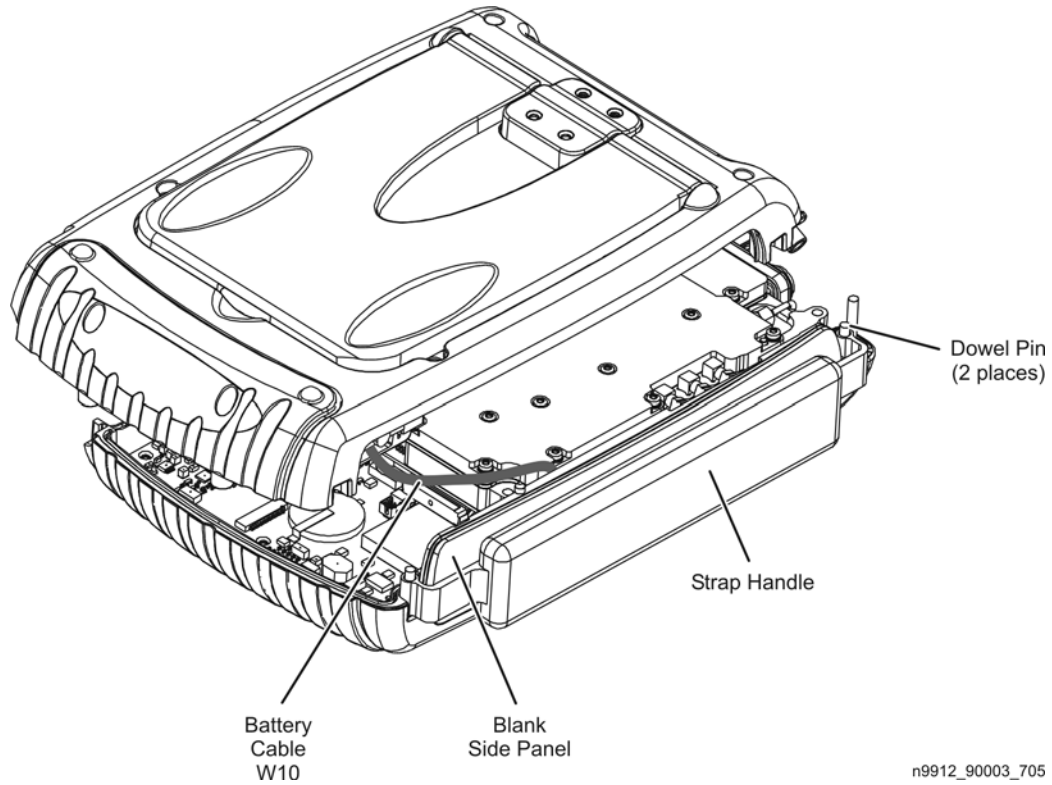

n9912_90003_705

7. Position the cases side-by-side as shown in [Figure 7-6](#).
8. Unplug the battery cable, W10, from the A5 system board at the location indicated.
9. The front and rear cases are now completely separated.
10. Remove the blank side panel by lifting it from the groove in the front case.

Figure 7-6 Separating the Front and Rear Cases (3)

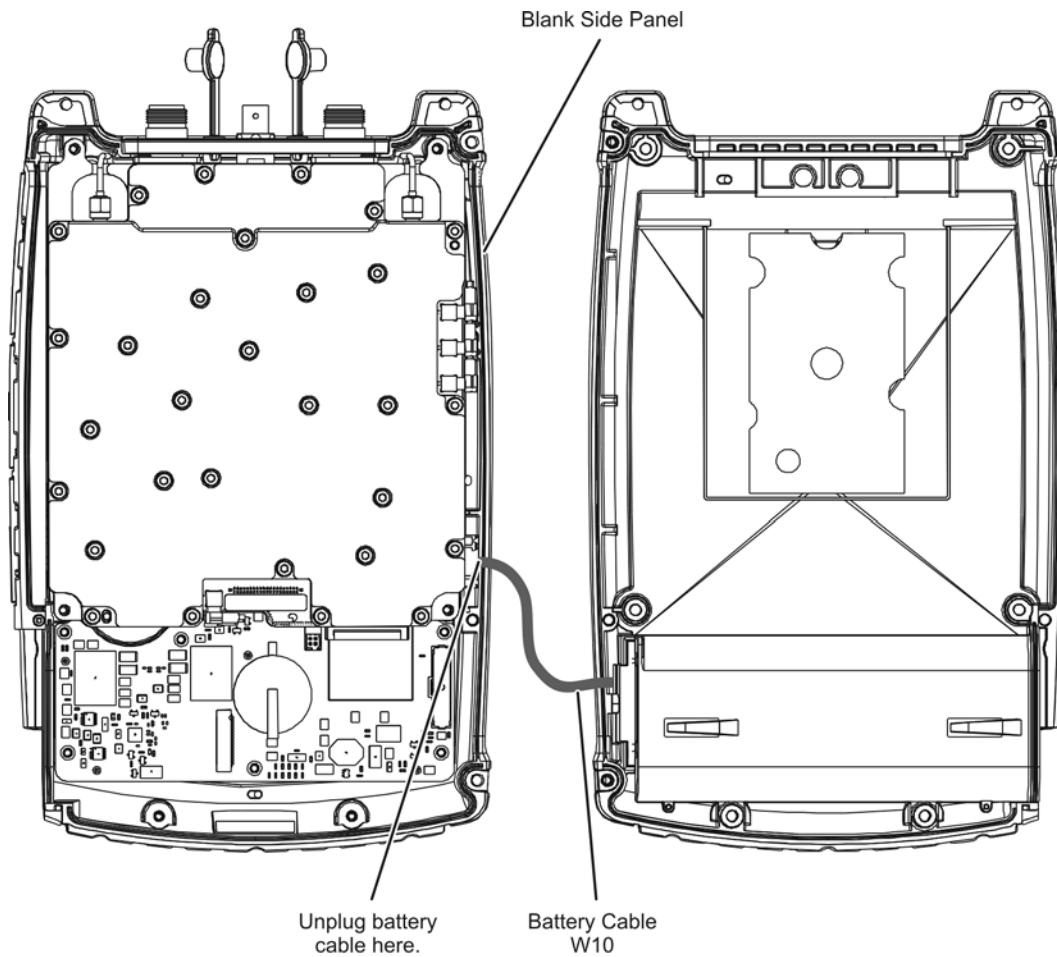

n9912_90003_706

Replacing the Battery Cable

1. Separate the front and rear cases. See [“Separating the Front and Rear Cases”](#) on page 7-8.
2. Note the orientation of the cable for installation of the new cable, then, using a small flat-blade screwdriver to move the cable connector, release the retention clips on the cable connector and remove the cable from the rear case. Do not over bend the retention clips as they could break.

Figure 7-7 Replacing the Battery Cable

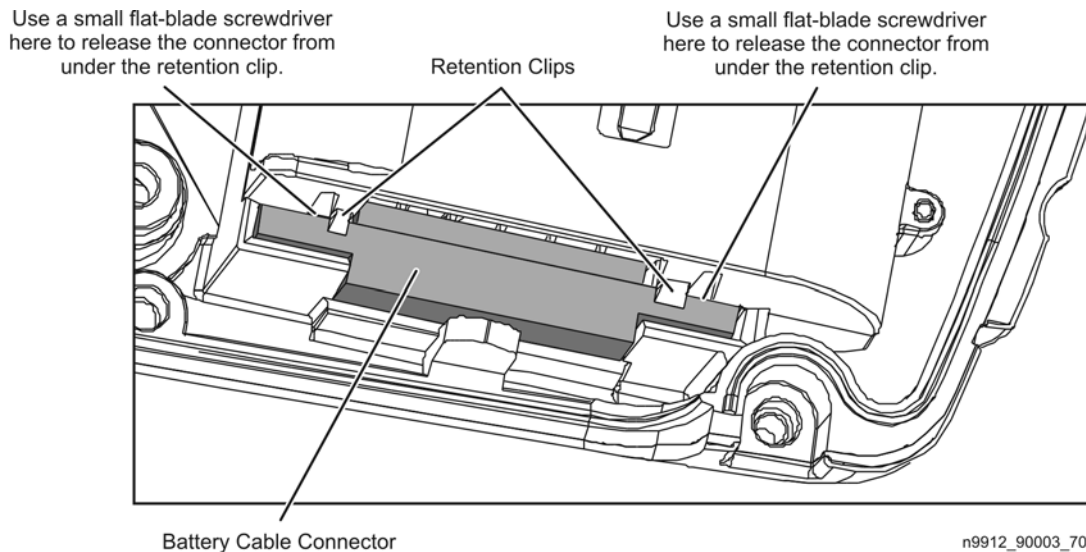

3. When installing the new battery cable, make sure that the connector snaps into place.
4. Reinstall the rear case onto the front case. See [Combining the Front and Rear Cases](#).

Replacing the Rear Case

1. Separate the front and rear cases. See [Separating the Front and Rear Cases](#).
2. Carefully remove the serial number label and the Windows CE label from the back of the old rear case and apply the labels to the new rear case.
3. Remove the kickstand assembly from the old rear case and install it on the new rear case. See [Replacing the Kickstand, Hinge Cover, and Hinge](#).
4. Remove the battery cable from the old case and install it in the new case. See [Replacing the Battery Cable](#).
5. Install the new rear case onto the front case. See [Combining the Front and Rear Cases](#).

Replacing the Strap Handle

1. Separate the front and rear cases to the positions shown in [Figure 7-5](#). See [Separating the Front and Rear Cases](#).
2. Note the orientation of the strap handle, then lift it off of the dowel pins at each end.

3. Slip the new strap handle over the dowel pins.
4. Reinstall the rear case onto the front case. See [Combining the Front and Rear Cases](#).

Replacing the I/O Side Panel, Doors, and Gasket

1. Separate the front and rear cases. See [“Separating the Front and Rear Cases”](#) on page 7-8.
2. Remove the measurement group assemblies (RF top panel assembly, A4 RF board, A5 system board, and A6 SOM board) as one unit with the I/O panel attached, but do not disconnect cable W11 from between the A2 LCD and the A5 system board. Refer to [“Removing and Replacing the Measurement Group Assemblies”](#) on page 7-25.
3. Remove the two screws (item 5) that secure the I/O side panel to the A5 system board and remove the I/O side panel.

Figure 7-8 Replacing the I/O Side Panel

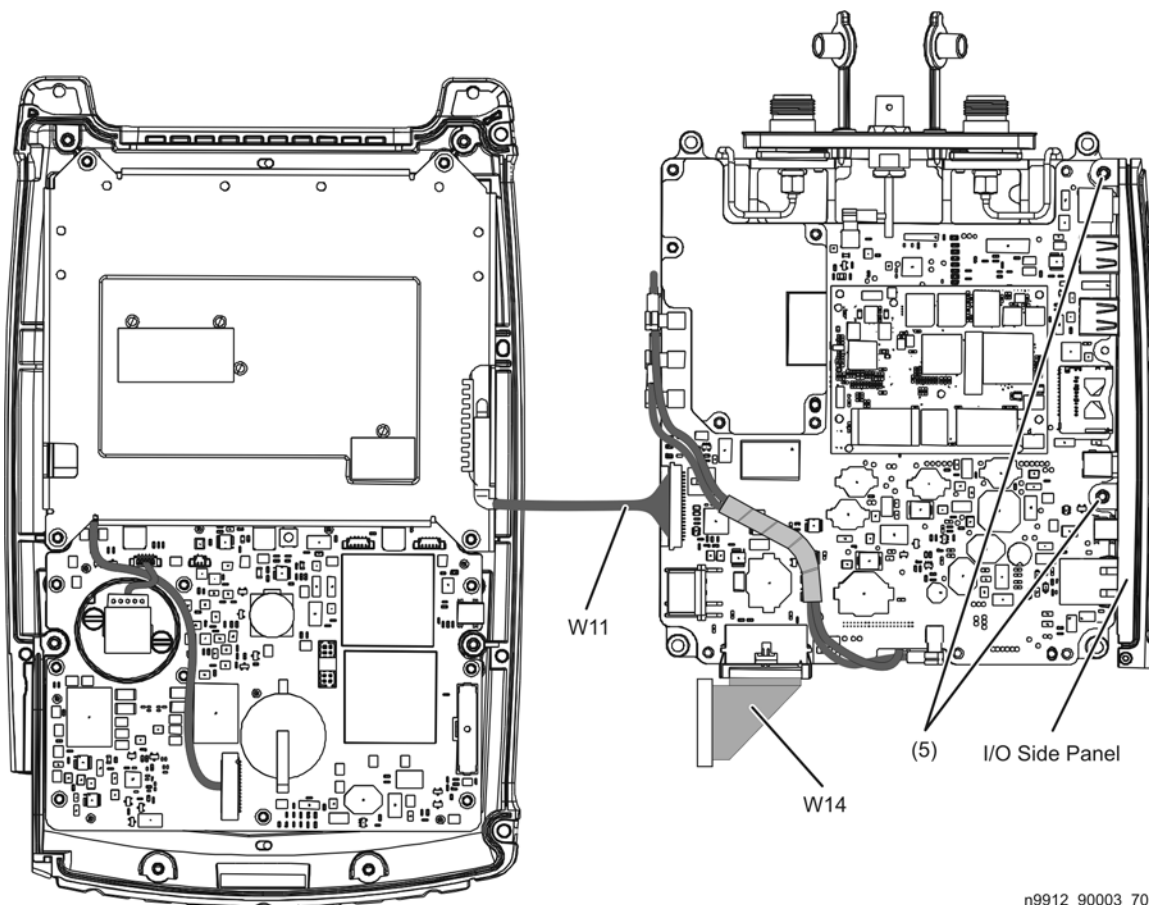

n9912_90003_708

4. Remove the three doors from the old I/O side panel:
 - a. Open each door to its stopping point, then GENTLY force it beyond its stopping point to separate it from the panel.
5. Install the three doors in the new I/O side panel:
 - a. Place each door in its respective opening with the hinges aligned with the hinge slots in the side panel.
 - b. Press the hinges into their slots until they snap into place.

Figure 7-9 Replacing the I/O Side Panel Doors and Gasket

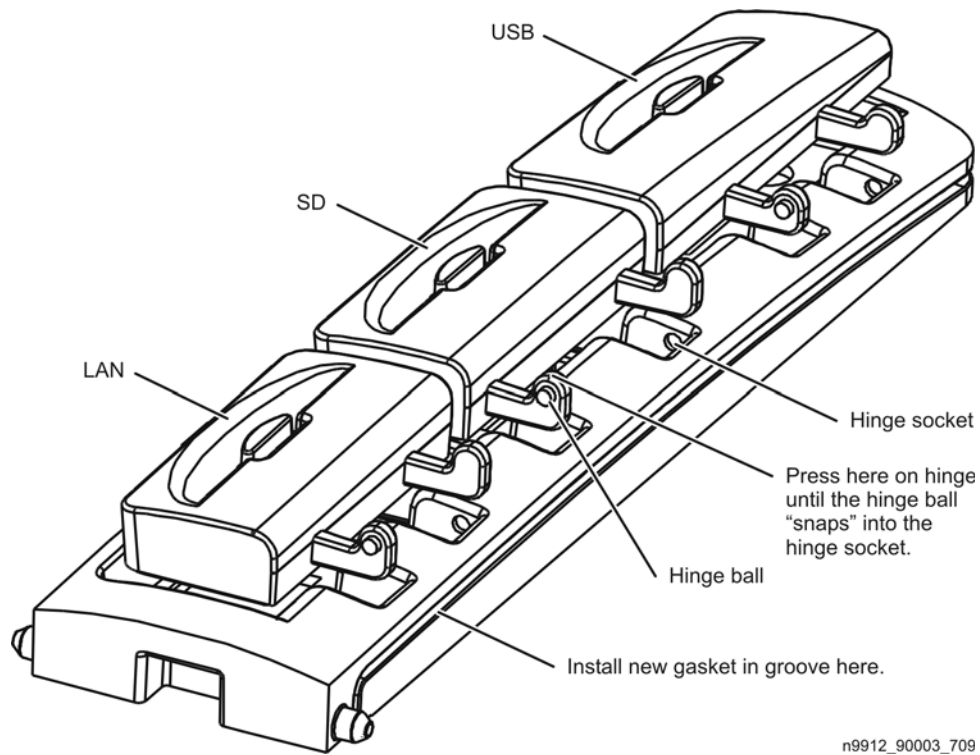

6. Before installing the new I/O side panel, or when reinstalling the existing I/O side panel, install a new gasket in the groove around the perimeter of the panel.

If an old gasket must be removed, use tweezers being careful not to damage the groove.

Start in the groove near the flat end of the side panel. Be careful not to stretch or damage the gasket in any way. Also, make sure there is no slack in the gasket. A new gasket is provided in the [Repair and Re-assembly Kit](#) (see [page 6-12](#)). It is the smaller of the two gaskets provided in the kit.
7. To install the new I/O side panel, place it in position on the A5 system board and reinstall the two attachment screws. See [Figure 7-8](#).
8. Reinstall the measurement group assemblies (RF top panel assembly, A4 RF board, A5 system board, and A6 SOM board) as one unit with the new I/O panel attached.
9. Reinstall the rear case onto the front case. See [Combining the Front and Rear Cases](#).

Replacing the Front Case (including the A1 Keypad)

1. Separate the front and rear cases. See [Separating the Front and Rear Cases](#).
2. Remove the measurement group assemblies (RF top panel assembly, A4 RF board, A5 system board, and A6 SOM board) as one unit with the I/O panel attached. Refer to [“Removing and Replacing the Measurement Group Assemblies”](#) on page 7-25.
3. Remove the front panel group assemblies (A2 LCD, A3 front panel interface board, and RPG). Refer to [“Removing and Replacing the Front Panel Group Assemblies”](#) on page 7-18.

Figure 7-10 Replacing the Front Case

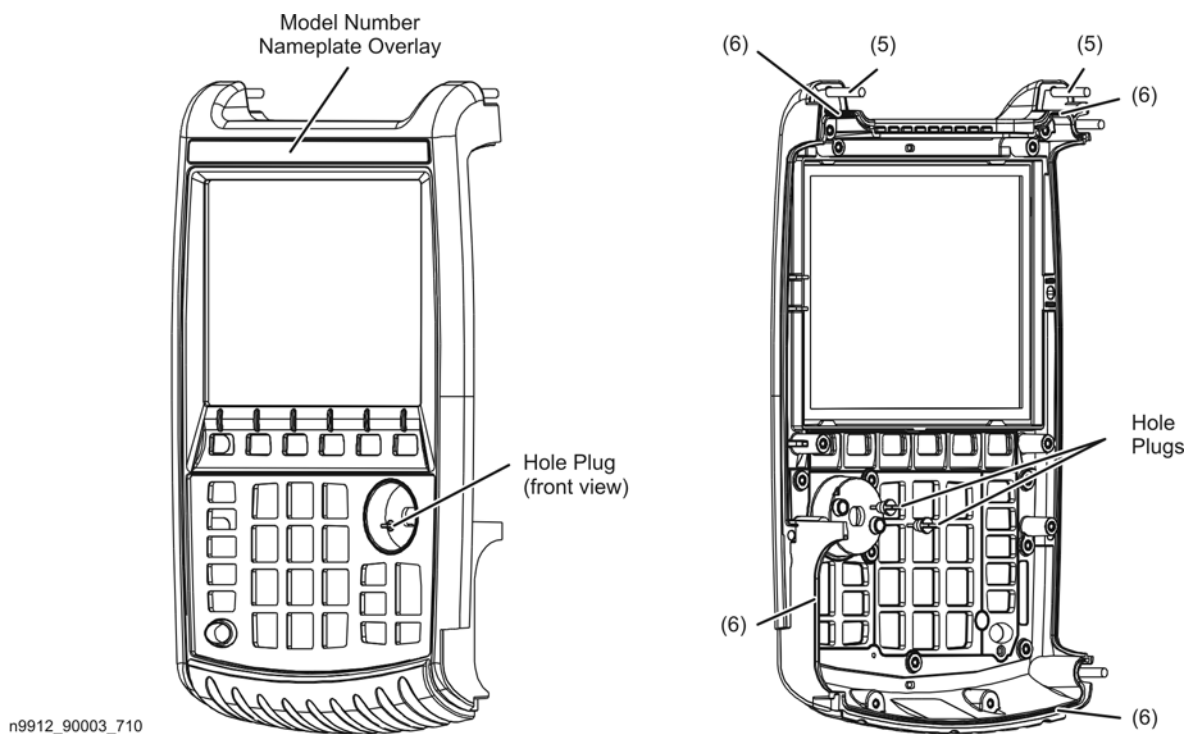

4. Carefully remove the serial number label from the inside bottom of the old front case and apply the label to the new front case.
5. Choose the appropriate model number nameplate overlay for your analyzer, remove the protective backing to expose the adhesive, and adhere it in the location shown.
6. Remove the dowel pins (item 5) from the old front case and install them in the new case. The other two dowel pins should already be installed in the case.
7. Make sure that the gaskets (item 6) are all in place in the grooves, that there are no gaps, and that they are not damaged in any way.
8. Refer to [“Removing and Replacing the Front Panel Group Assemblies”](#) on page 7-18 to reinstall the front panel group assemblies removed in step 3.
9. Refer to [“Removing and Replacing the Measurement Group Assemblies”](#) on page 7-25 to reinstall the measurement group assemblies removed in step 2.

10. Reinstall the rear case onto the front case. Refer to “Combining the Front and Rear Cases” on page 7-15.

Combining the Front and Rear Cases

1. Install a new gasket on the blank side panel being careful not to stretch it or to damage it in any way. Also, make sure there is no slack in the gasket. A new gasket is provided in the [Repair and Re-assembly Kit](#) (the blank side panel uses the larger of the two gaskets provided). If an old gasket must be removed, carefully remove it with tweezers being careful not to damage the groove.
2. If a new gasket has not been installed on the I/O side panel, install it at this time. It will be necessary to remove the I/O side panel from the A5 system board. Refer to “[Replacing the I/O Side Panel, Doors, and Gasket](#)” on page 7-12 for instructions.
3. Position the front and rear cases side-by-side as shown.
4. Plug the battery cable, W10, into the A5 system board as indicated.

Figure 7-11 Combining the Front and Rear Cases (1)

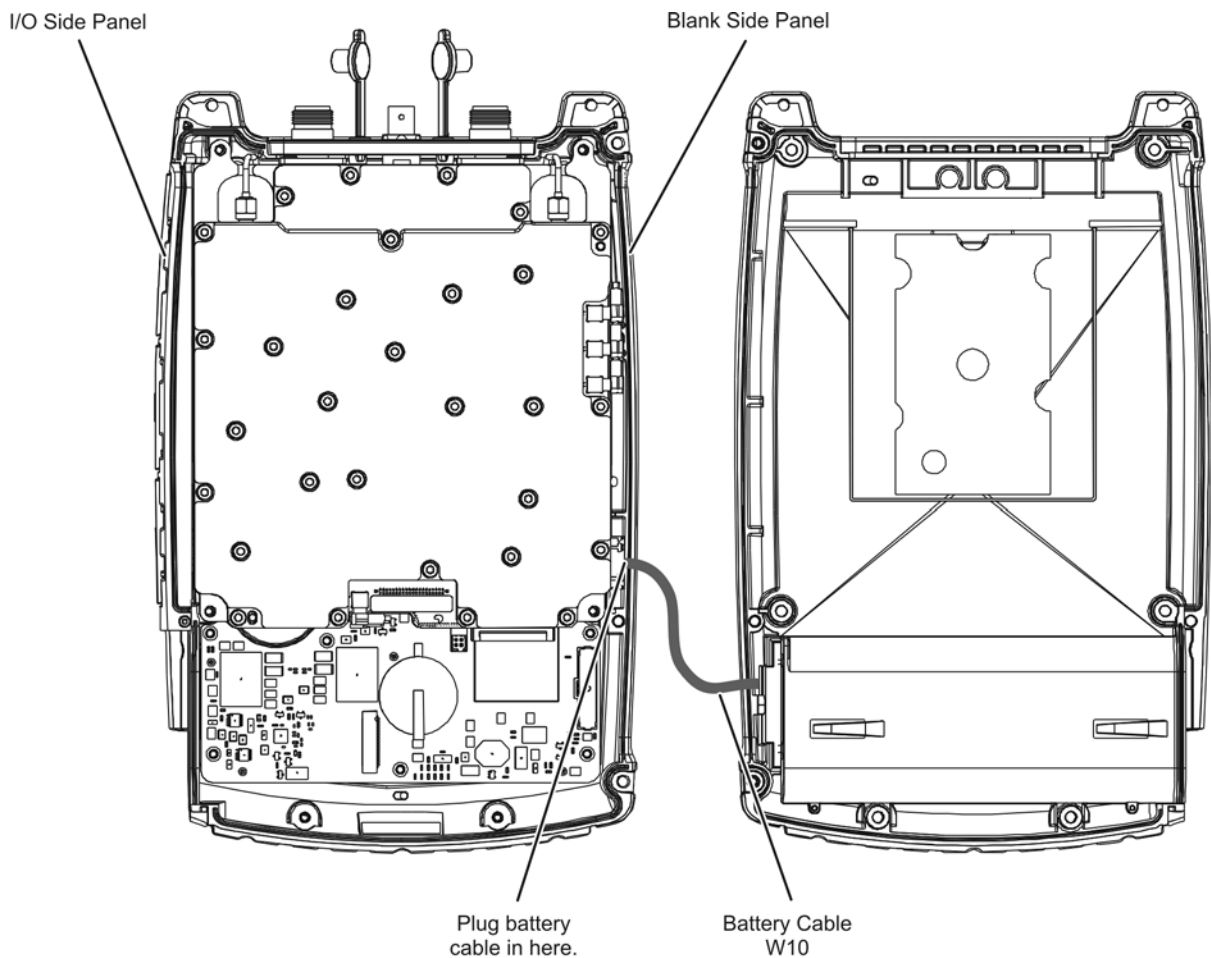

n9912_90003_711

5. Position the rear case on top of the front case and to one side as shown.
6. Place the blank side panel in the groove in the front case being careful not to damage the gasket.
7. Position the strap handle over the two dowel pins as shown.

Figure 7-12 Combining the Front and Rear Cases (2)

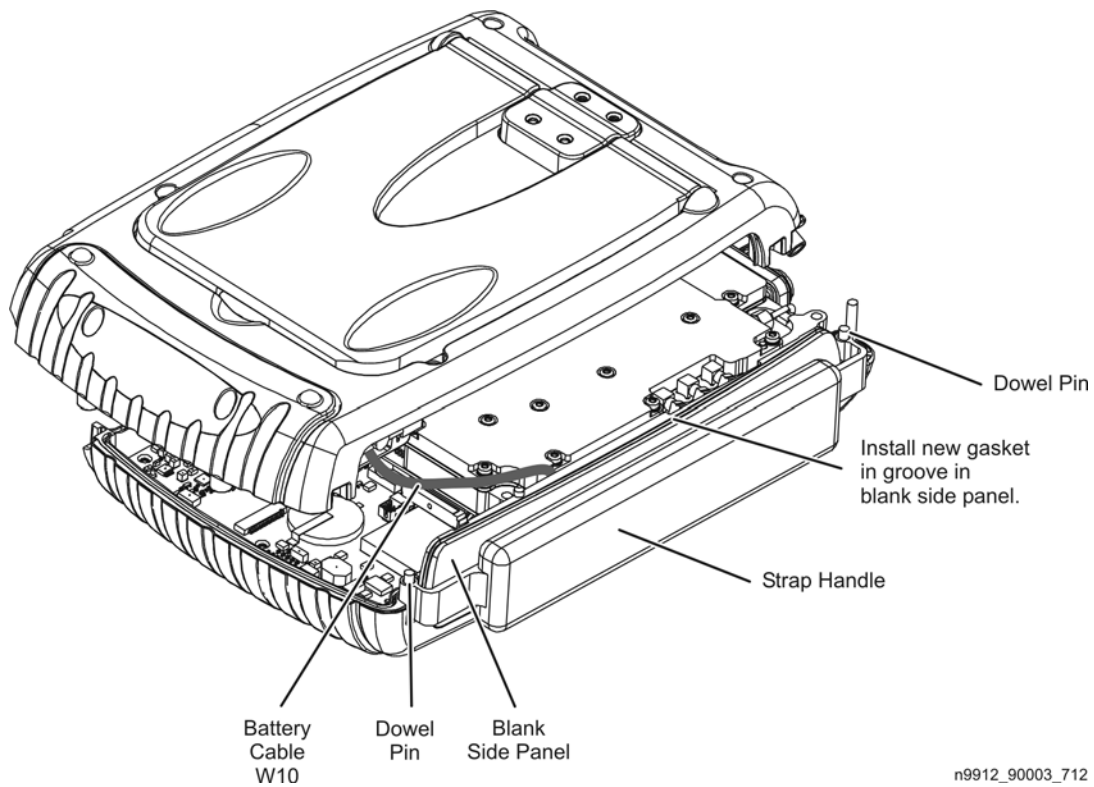

n9912_90003_712

8. Position the rear case directly over, and aligned with, the front case and the side panels as shown.
9. Make sure the battery cable is tucked in between the measurement group assemblies and the blank side panel and that it is not in the path of the screw hole indicated.
10. Firmly press the cases together being careful not to damage the gaskets.
11. Install six new screws (item 7) to secure the rear case to the front case. These new screws are provided in the [Repair and Re-assembly Kit](#).
12. Tighten the six screws (item 8) that secure the RF top panel.

Figure 7-13 Combining the Front and Rear Cases (3)

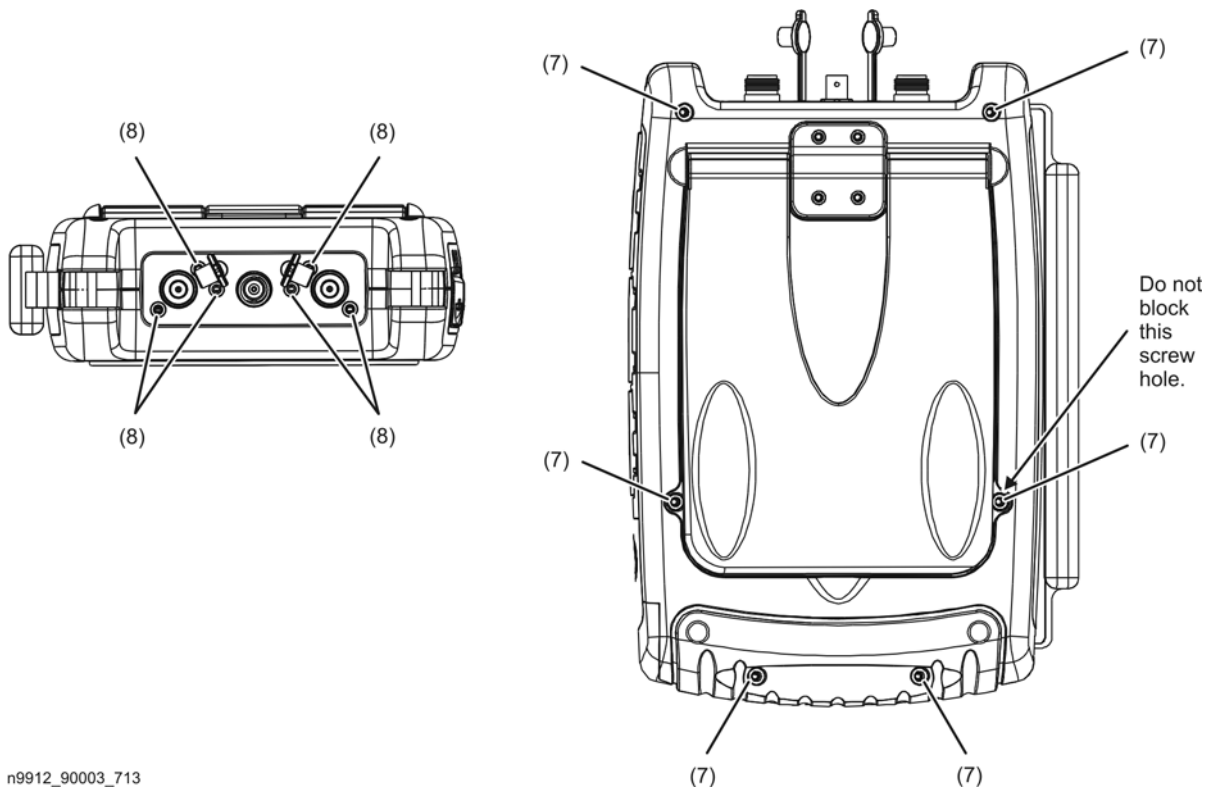

13. Reinstall the battery. Refer to [“Removing and Replacing the Main Battery”](#) on page 7-5.

Removing and Replacing the Front Panel Group Assemblies

Tools Required

- T-8 TORX driver (set to 6 in-lb)
- T-10 TORX driver (set to 9 in-lb)
- 7/16-inch hex nut wrench or “nut driver” (set to 9 in-lb)
- [Repair and Re-assembly Kit](#). Refer to “[Miscellaneous Parts](#)” on page 6-12.
- Soldering tool (Required only for RTC battery replacement.)

WARNING Before beginning any repair, disconnect the power cord.

Pre-replacement Procedure

1. Separate the front and rear cases. Refer to “[Separating the Front and Rear Cases](#)” on page 7-8.
2. Remove the measurement group assemblies (RF top panel, A4 RF board, A5 system board, and A6 SOM board) as one unit with the I/O panel attached. Refer to “[Removing and Replacing the Measurement Group Assemblies](#)” on page 7-25.

Replacing the RPG and RPG Knob

1. Perform the steps under “[Pre-replacement Procedure](#)” on page 7-18.
2. Remove the two hole plugs from the back side of the front case, next to the RPG.
3. To replace the RPG knob:
 - a. Insert a round shaft, such as a screwdriver shaft, into the exposed holes and push the RPG knob off of the RPG shaft to the front side of the front case.
 - b. Install a new knob by aligning the D-shaped detent in the knob with the D-shape on the shaft and push the knob into position.
4. To replace the RPG:
 - a. Remove the RPG knob. Refer to step 3.a of this procedure.
 - b. Disconnect the RPG cable, W12, from the A3 front panel interface board.
 - c. Using a 7/16-inch hex nut wrench, remove the hex nut from the RPG shaft.
 - d. Pull the RPG out the back side of the front case and retrieve the lock washer from the front side.
 - e. To install a new RPG, reverse the above steps. A new cable, nut, and washer are included with the new RPG. When reinstalling the RPG cable, W12, bend the cable toward the right side on top of the display to front panel interface board cable.
5. Reinstall the hole plugs in the front case. Apply one drop of isopropyl alcohol on each hole plug to lubricate it, making it easier to install. **Use alcohol only in a well**

ventilated area. View the hole plugs from the front to ensure that they are fully seated. These hole plugs must be installed to maintain water-tight integrity.

6. Reinstall the RPG knob. Refer to step 3.b of this procedure.
7. Perform the steps under “[Post-replacement Procedure](#)” on page 7-24.

Figure 7-14 Replacing the RPG and RPG Knob

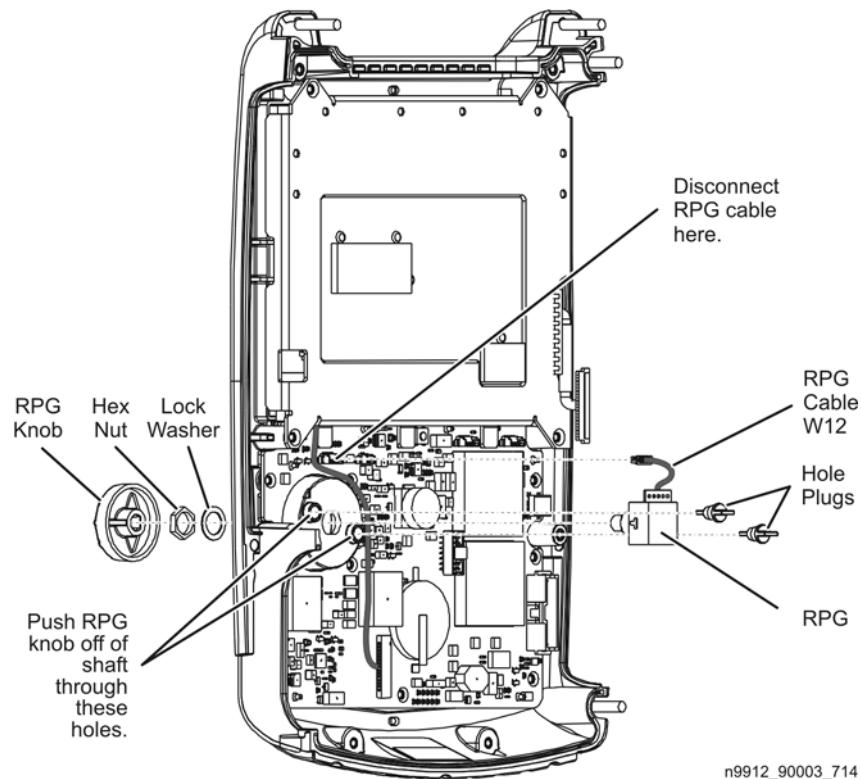

Replacing the A2 LCD, the LCD Shield, and LCD Cables

1. Perform the steps under “[Pre-replacement Procedure](#)” on page 7-18.
2. To replace the LCD shield:
 - a. Remove the four screws (item 1) that attach the LCD shield and discard them. New screws are provided in the [Repair and Re-assembly Kit](#).
 - b. Lift the LCD shield off of the A2 LCD.
 - c. Install new gap pads on the new LCD shield in the locations shown. Refer to [Figure 7-15](#) and [Figure 7-8 on page 7-12](#) for placement of gap pads.
 - d. Place the new LCD shield in position on the A2 LCD and secure it with four new screws (item 1). These screws are provided in the [Repair and Re-assembly Kit](#).
3. To replace the LCD cables and the A2 LCD:
 - a. Remove the LCD shield. Refer to steps [2.a](#) and [2.b](#) of this procedure.
 - b. Disconnect the A2 LCD to A3 FPIB cable, W13, at the A2 LCD. If replacing only this cable:
 1. Disconnect the cable at both ends.
 2. Remove the cable from beneath the RPG cable, W12.
 3. Route the new cable beneath the RPG cable as shown and re-connect both ends.
 4. Bend the RPG cable toward the right side as shown.
 5. Skip to step [3.h](#).
 - c. Note the location of the adhesive tape over the connector on the A2 LCD to A5 system board cable, W11. Remove the tape and disconnect the cable. If replacing only this cable:
 1. Connect the new cable.
 2. Skip to step [3.h](#).
 - d. Remove the A2 LCD from the front case.
 - e. Place the new A2 LCD in position and re-connect the cables.
 - f. Place a strip of adhesive tape over the LCD connector end of the A2 LCD to A5 system board cable W11, in the same location as the old strip and as shown. A new strip of adhesive tape is provided in the [Repair and Re-assembly Kit](#).
 - g. Connect cable W13 to the A2 LCD.
 - h. Reinstall the LCD shield with four new screws provided in the [Repair and Re-assembly Kit](#). Refer to step [Step d on page 7-20](#) of this procedure.
4. Perform the steps under “[Post-replacement Procedure](#)” on page 7-24.

Figure 7-15 Replacing the A2 LCD, the LCD Shield, and LCD Cables

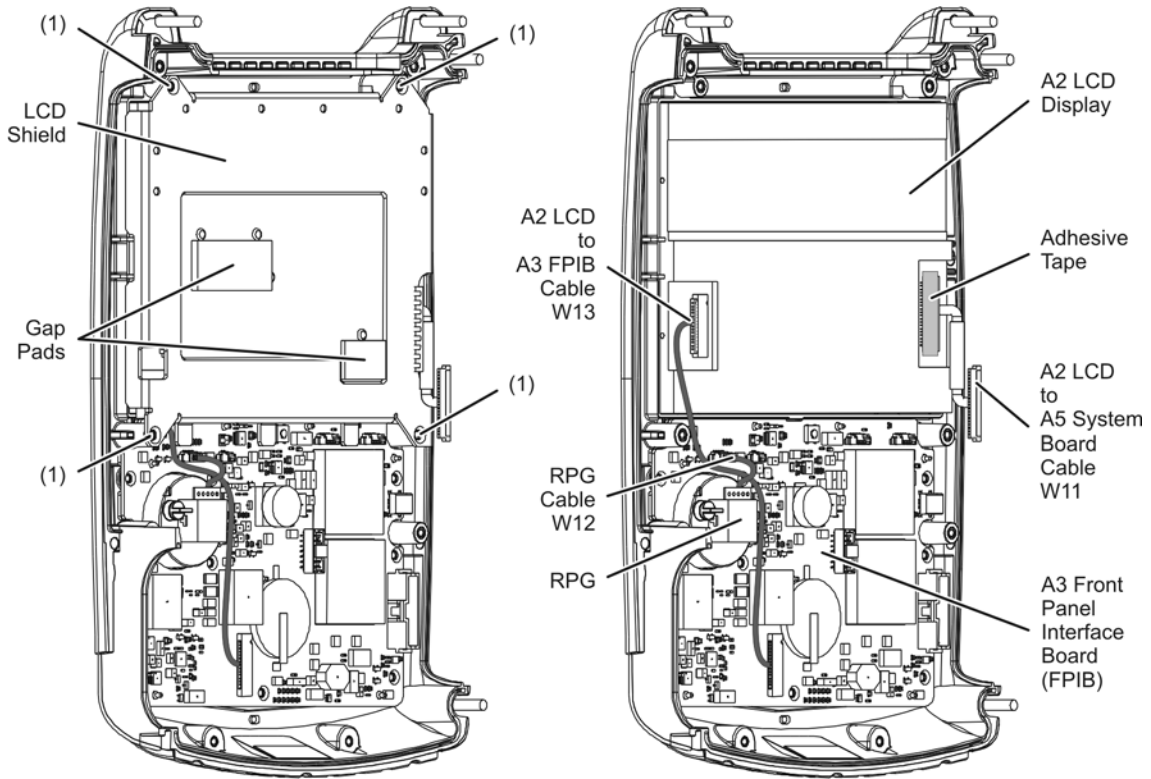

n9923_90005_715

Replacing the A3 Front Panel Interface Board (FPIB)

IMPORTANT The A3 front panel interface board contains a Lithium-ion battery. Refer to [“Battery Disposal” on page 1-7](#) for important instructions on disposing of this printed circuit board with the battery attached. If necessary, the battery can be removed from the printed circuit board and disposed of separately.

1. Perform the steps under [“Pre-replacement Procedure” on page 7-18](#).
2. Remove the four screws (item 2) that secure the LCD shield and remove the LCD shield. Discard the four screws, new ones are provided in the [Repair and Re-assembly Kit](#). **Be careful. The A2 LCD display is now loose and will fall out of the front case if the case is tipped.**
3. Disconnect the RPG cable, W12, at the A3 FPIB connector as indicated.
4. Disconnect the A2 LCD to FPIB cable, W113, at the A3 FPIB connector as indicated.
5. Remove the nine screws (item 3) that secure the A3 FPIB to the front case.
6. Push the nine rubber “nubs” through the A3 FPIB to release the A1 keypad. The A1 keypad is permanently attached to the front case and must remain.
7. Position the new A3 FPIB in the front case over the A1 keypad and, using needle-nose pliers, pull the nine rubber “nubs” on the A1 keypad through the holes in the A3 FPIB. Make sure that all nine of the rubber “nubs” are fully extended on the back side of the A3 FPIB.
8. Secure the A3 FPIB to the front case with nine new screws (item 3) provided in the [Repair and Re-assembly Kit](#).
9. Re-connect the A2 LCD to FPIB cable, W13, to the A3 FPIB connector as indicated. Route the cable as shown.
10. Re-connect the RPG cable, W12, to the A3 FPIB connector as indicated, with the A2 LCD to A3 FPIB cable, W13, passing beneath it as shown. Bend the RPG cable toward the right side as shown.
11. Place the LCD shield back in position on the A2 LCD. Make sure that the A2 LCD to A3 FPIB cable, W13, is routed between, not under, the shield gaskets.
12. Secure the shield with four new screws (item 2) provided in the [Repair and Re-assembly Kit](#).
13. Perform the steps under [“Post-replacement Procedure” on page 7-24](#).

Figure 7-16 Replacing the A3 Front Panel Interface Board

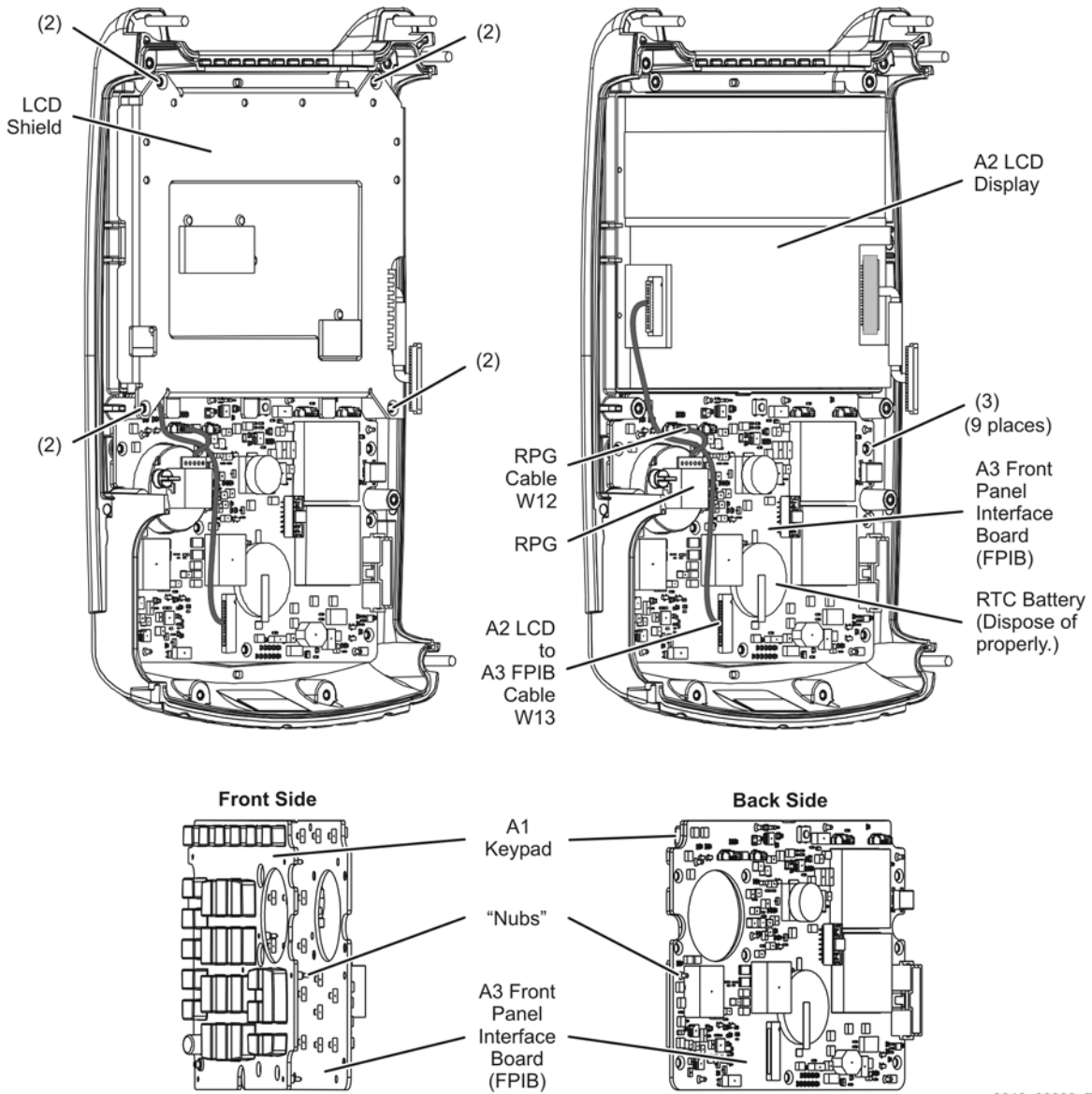

n9912_90003_716

Replacing the Real Time Clock (RTC) Battery Located on the A3 Front Panel Interface Board (FPIB)

IMPORTANT The RTC battery is a Lithium-ion battery and must be disposed of properly. Refer to [“Battery Disposal”](#) on page 1-7 for important instructions on disposing of this battery .

NOTE A soldering tool is required for this procedure.

1. Perform the steps under [“Pre-replacement Procedure”](#) on page 7-18.
2. Unsolder the RTC battery from the A3 FPIB.
3. Insert and solder the new RTC battery into place.
4. Perform the steps under [“Post-replacement Procedure”](#) on page 7-24.

Figure 7-17 Replacing the RTC Battery

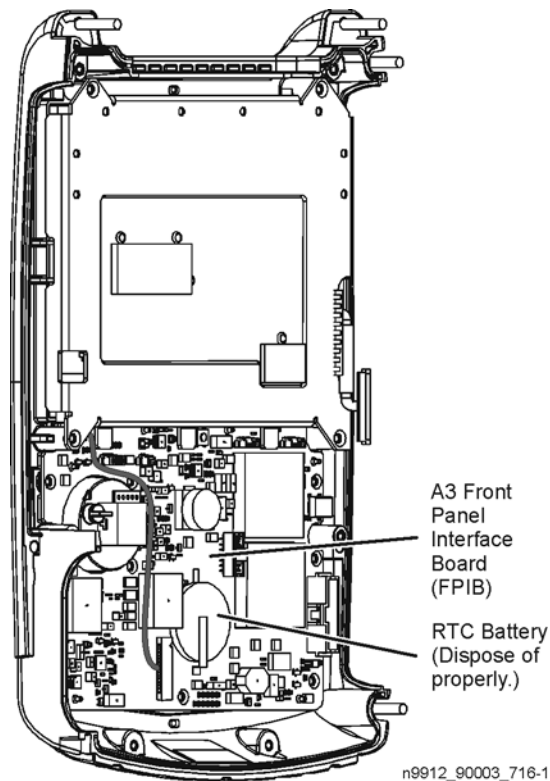

Post-replacement Procedure

1. Reinstall the measurement group assemblies (RF top panel, A4 RF board, A5 system board, and A6 SOM board) as one unit with the I/O panel attached. Refer to [“Removing and Replacing the Measurement Group Assemblies”](#) on page 7-25.
2. Combine the front and rear cases. Refer to [“Combining the Front and Rear Cases”](#) on page 7-15.

Removing and Replacing the Measurement Group Assemblies

Tools Required

- T-8 TORX driver (set to 6 in-lb)
- T-10 TORX driver (set to 9 in-lb)
- 5/16-inch open-end torque wrench (set to 10 in-lb)
- 9/16-inch open-end torque wrench (set to 21 in-lb)
- [Repair and Re-assembly Kit](#). Refer to “Miscellaneous Parts” on page 6-12.

WARNING Before beginning any repair, remove the battery and disconnect external power.

Removing All Measurement Group Assemblies as One Unit

1. Separate the front and rear cases. Refer to “[Separating the Front and Rear Cases](#)” on page 7-8.
2. Disconnect the A5 system board to A3 FPIB cable, W14, at the A3 FPIB connector. If replacing this cable, disconnect both ends.
3. Lift the measurement group assemblies out of the front case and position them to the side of the front case as shown.
4. Disconnect the A2 LCD to A5 system board cable, W11, at the A5 system board connector. It is necessary to first remove the adhesive tape that is over the connector. To replace this cable, refer to “[Replacing the A2 LCD, the LCD Shield, and LCD Cables](#)” on page 7-20.
5. The measurement group assemblies are now completely separated from the analyzer.
6. To remove the I/O panel, refer to “[Replacing the I/O Side Panel, Doors, and Gasket](#)” on page 7-12.

Figure 7-18 Removing All Measurement Group Assemblies as One Unit

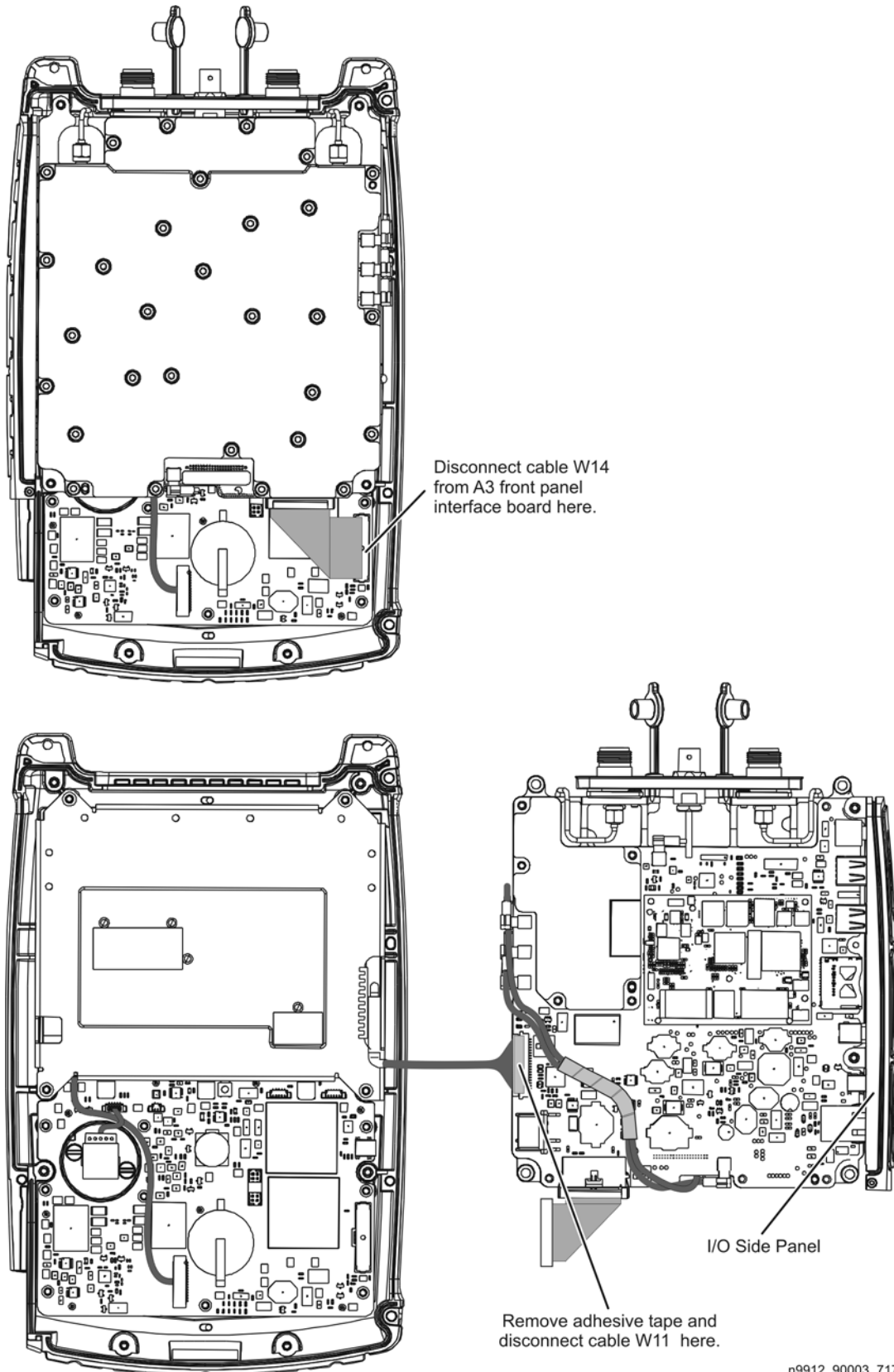

n9912_90003_717

Replacing the RF Top Panel Assembly

1. Separate the front and rear cases. Refer to “[Separating the Front and Rear Cases](#)” on page 7-8.
2. Remove all measurement group assemblies as one unit. Refer to “[Removing All Measurement Group Assemblies as One Unit](#)” on page 7-25.
3. Unplug the two connector plugs (tethered caps) from the type-N RF connectors.
4. Disconnect cable W3.
5. Remove the six screws (item 1) and lift the RF top panel over the type-N RF connectors.
6. Position the new RF top panel over the type-N RF connectors and loosely reinstall the six screws (item 1). Do not tighten these screws at this time; they will be tightened after the front and rear cases have been combined.
7. Connect cable W3 to the A5 system board connector. There should be an audible click when the connector is fully in place.
8. Position (tuck) the cable W3 into the cavity above the A5 system board to avoid interference with nearby parts.
9. Plug the two connector plugs (tethered caps) back into the type-N RF connectors to protect the connectors.
10. Perform the steps under “[Post-replacement Procedure](#)” on page 7-37.

Figure 7-19 Replacing the RF Top Panel Assembly

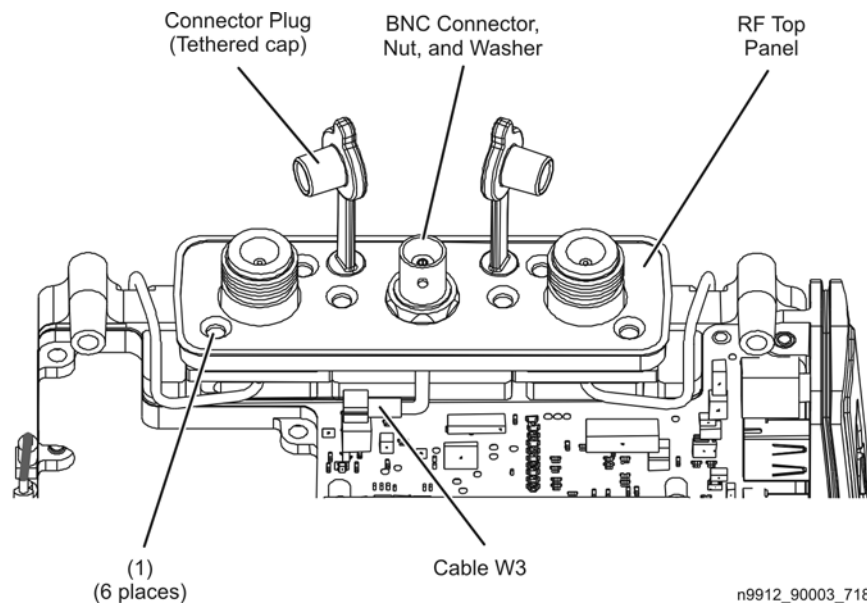

Replacing the Type-N RF Connectors and RF Cables

1. Separate the front and rear cases. See “Separating the Front and Rear Cases” on page 7-8.
2. Remove all measurement group assemblies as one unit. Refer to “Removing All Measurement Group Assemblies as One Unit” on page 7-25.
3. Remove the RF top assembly. Refer to “Replacing the RF Top Panel Assembly” on page 7-27.
4. Disconnect the cable connector nut on cable W1 or W2, depending on which connector or cable is being replaced. Do not attempt to remove the cable, just release the connector nut.
5. Remove the two screws (item 2) from the type-N RF connector to be replaced.
6. Lift the type-N RF connector upwards and out of the RF bottom shield.
7. The PORT 2put cable can now be replaced by disconnecting the other end of the cable and removing it. When installing the new cable, do not tighten either of the cable connector nuts until both of them have been installed finger tight.
8. Remove the RFI O-ring.
9. Remove the old insulator and install a new one.
10. Position the new type-N RF connector in the RF bottom shield, making sure that it aligns with the cable connector underneath. Loosely install the cable connector nut.
11. Install a new RFI O-ring over the new type-N RF connector in the position shown.
12. Loosely reinstall the two screws (item 2). Note the location for these two screws in the illustration. To ensure proper alignment, install two additional screws, finger tight, in the two empty holes in the type-N RF connector, then tighten the two screws that secure the connector. Remove the two alignment screws.
13. Tighten the cable connector nut(s) on cable W1 or W2.
14. Perform the steps under “Post-replacement Procedure” on page 7-37.

Figure 7-20 Replacing the Type-N RF Connectors and RF Cables

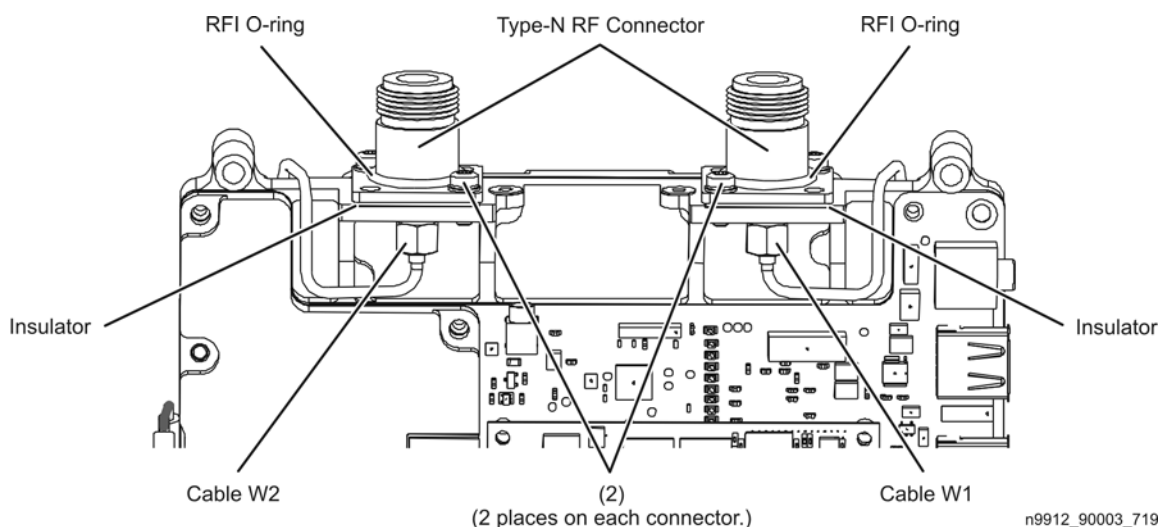

Replacing the A6 SOM Board and Flexible RF Cables

1. Separate the front and rear cases. Refer to [“Separating the Front and Rear Cases” on page 7-8](#).
2. Remove all measurement group assemblies as one unit. Refer to [“Removing All Measurement Group Assemblies as One Unit” on page 7-25](#).
3. To replace the A6 SOM board:
 - a. Remove the four screws (item 3) that secure the A6 SOM board. Discard these screws; new ones are provided in the [Repair and Re-assembly Kit](#).
 - b. Unplug the A6 SOM board from the A5 system board.
 - c. Plug the new A6 SOM board into the A5 system board.
 - d. Install four new screws (item 3) from the [Repair and Re-assembly Kit](#) and tighten them in the torque sequence indicated by the circled numbers (①②③④) in the illustration.
4. To replace the flexible RF cables:
 - a. To aid in reinstallation, note the connector to which each cable end is connected before disconnecting the cable. Refer to [Figure 5-1 on page 5-4](#) for an electrical diagram of each cable connection.
 - b. Cables W4 and W6 are provided as an assembly. When replacing this coax cable assembly:
 1. Make sure the cable connectors are positioned as shown and that the cable assembly is routed as shown. Cable W6 is the one with a red mark on each connector.
 2. Ensure that there is no slack in the cables at the top connections as indicated.
 3. Make sure that the cable assembly does not touch the TCXO chip on the A5 system board.
 4. Clip cable W6 into each of the cable clamps on the A5 system board. Cable W6 is the one with a red mark on each connector.
 - c. To replace cable W5 or W7:
 1. Disconnect the appropriate cable and install the new cable being sure to position it as shown.
5. To remove the I/O panel, refer to [“Replacing the I/O Side Panel, Doors, and Gasket” on page 7-12](#).
6. Perform the steps under [“Post-replacement Procedure” on page 7-37](#).

Figure 7-21 Replacing the A6 SOM Board and Flexible RF Cables

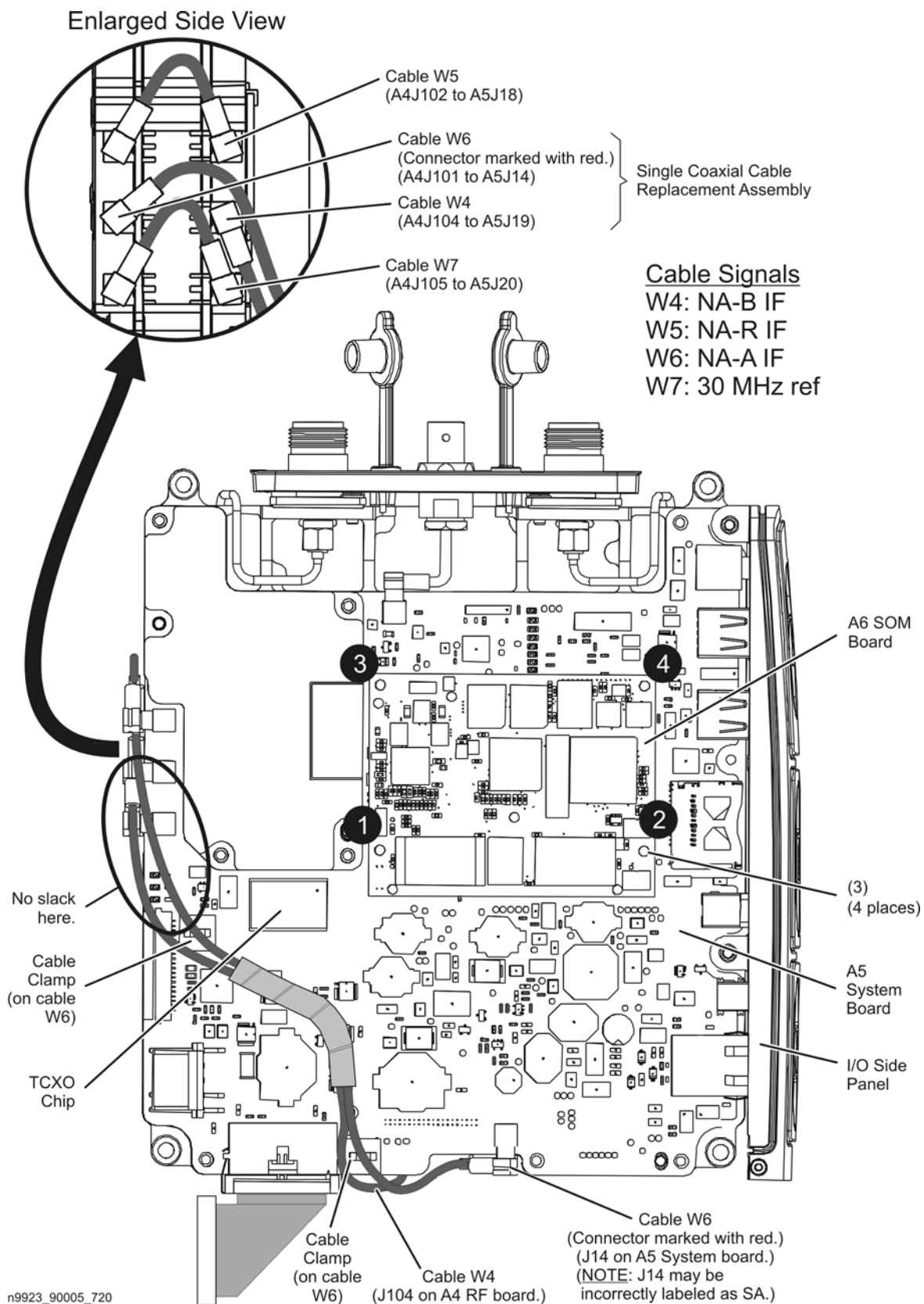

Replacing the A5 System Board

1. Separate the front and rear cases. See [“Separating the Front and Rear Cases” on page 7-8](#).
2. Remove all measurement group assemblies as one unit. Refer to [“Removing All Measurement Group Assemblies as One Unit” on page 7-25](#).
3. Remove the I/O side panel. Refer to [“Replacing the I/O Side Panel, Doors, and Gasket” on page 7-12](#).
4. Remove the A6 SOM board and flexible RF cables. Refer to [“Replacing the A6 SOM Board and Flexible RF Cables” on page 7-29](#). Refer also to Enlarged Side View in the previous illustration. Note which cable is connected to which pc board connector to aid in reinstallation.
5. Disconnect cable W3 from the A5 system board.
6. Remove four screws (item 4) from the system board shield and remove the shield. Discard the screws, new ones are provided in the [Repair and Re-assembly Kit](#).
7. Remove six screws (item 5) from the A5 system board, lift it up from the RF bottom shield, and unplug it from the A4 RF board connector. Discard the screws, new ones are provided in the [Repair and Re-assembly Kit](#).
8. Remove the waffle gasket from the RF bottom shield and discard it. A new gasket is provided in the [Repair and Re-assembly Kit](#).
9. Manipulate the new waffle gasket by hand to eliminate curling and install it on the RF bottom shield using the three dowel pins for alignment. It is not necessary that the gasket be completely flat, just enough to remain in position while installing the new A5 system board.
10. Plug in the new A5 system board to the A4 RF board, over the new gasket, and aligned with the three dowel pins in the RF bottom shield.
11. Position a new waffle gasket, from the [Repair and Re-assembly Kit](#), for the system board top shield, on the A5 system board using the two dowel pins for alignment. Manipulate this gasket by hand to flatten it if necessary.
12. Reinstall the system board top shield over the gasket and aligned with the dowel pins.
13. Hand-tighten four new screws (item 4) to secure the system board top shield and six new screws (item 5) to secure the A5 system board to the RF bottom shield.
14. Torque these ten screws in the sequence shown by the circled numbers (①–⑩). Repeat this torque sequence one additional time.
15. Reinstall the A6 SOM board and reinstall or reconnect all coax cables that were removed or disconnected previously. Refer to [“Replacing the A6 SOM Board and Flexible RF Cables” on page 7-29](#).
16. Remove the system board to FPIB cable from the old A5 system board and install it on the new board.
17. Reinstall the I/O side panel. Refer to [“Replacing the I/O Side Panel, Doors, and Gasket” on page 7-12](#).
18. Perform the steps under [“Post-replacement Procedure” on page 7-37](#).

Figure 7-22 Replacing the A5 System Board

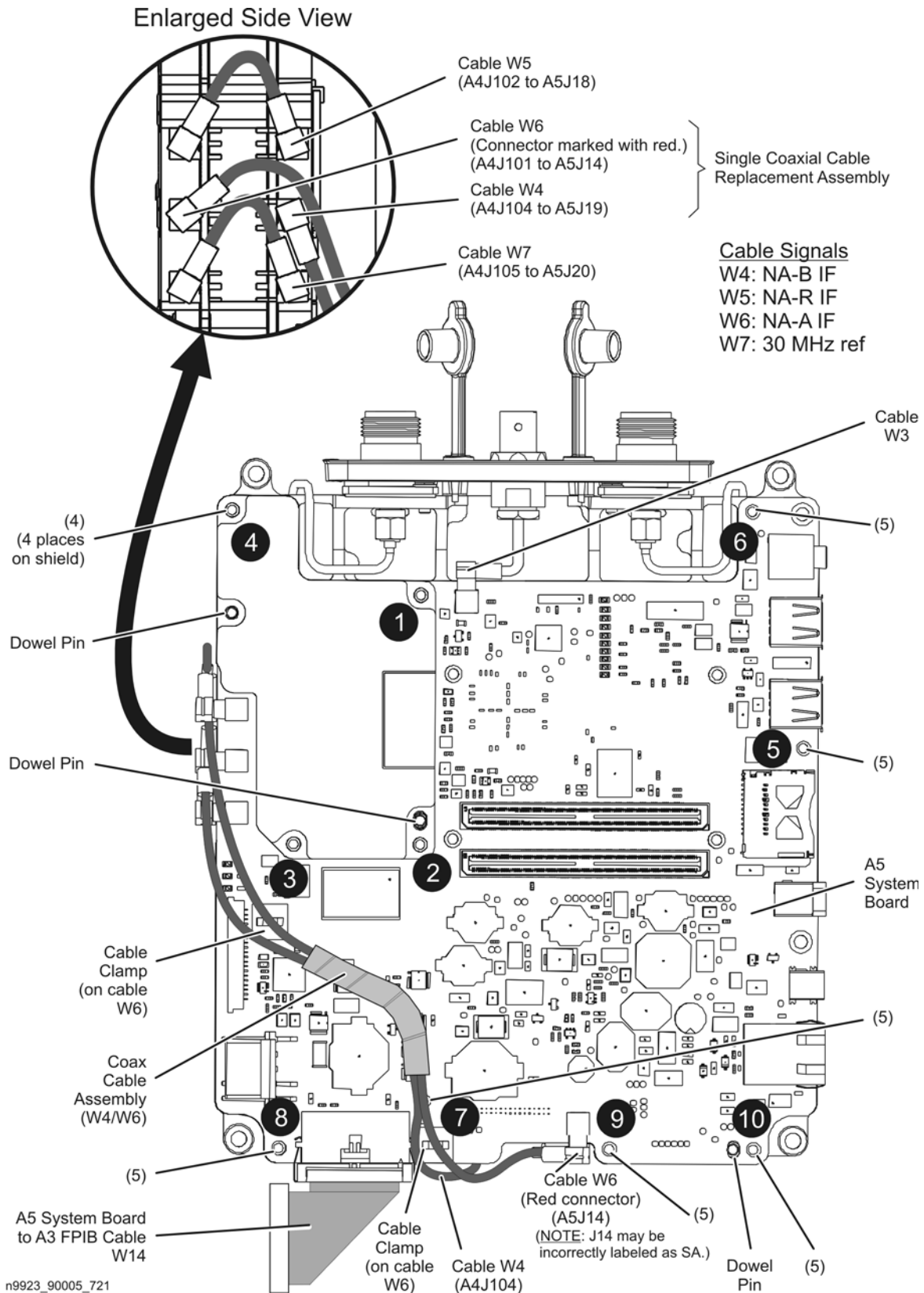

Replacing the RF Assembly Including the A4 RF Board

1. Separate the front and rear cases. Refer to [“Separating the Front and Rear Cases” on page 7-8](#).
2. Remove all measurement group assemblies as one unit. Refer to [“Removing All Measurement Group Assemblies as One Unit” on page 7-25](#).
3. Disconnect the flexible RF cables from the A4 RF board; it is not necessary to disconnect the cables from the A5 system board. Refer to [“Replacing the A6 SOM Board and Flexible RF Cables” on page 7-29](#).
4. Remove the A5 system board. Refer to [“Replacing the A5 System Board” on page 7-31](#).
5. Remove the BNC connector, nut, and washer from the old RF assembly and install them in the new RF assembly. Note: Cable W3 includes the BNC connector.
6. Reinstall the A5 system board onto the new RF assembly. Refer to [“Replacing the A5 System Board” on page 7-31](#).
7. Re-connect the flexible RF cables to the A4 RF board. Refer to [“Replacing the A6 SOM Board and Flexible RF Cables” on page 7-29](#).
8. Perform the steps under [“Post-replacement Procedure” on page 7-37](#).

Figure 7-23 Replacing the RF Assembly Including the A4 RF Board

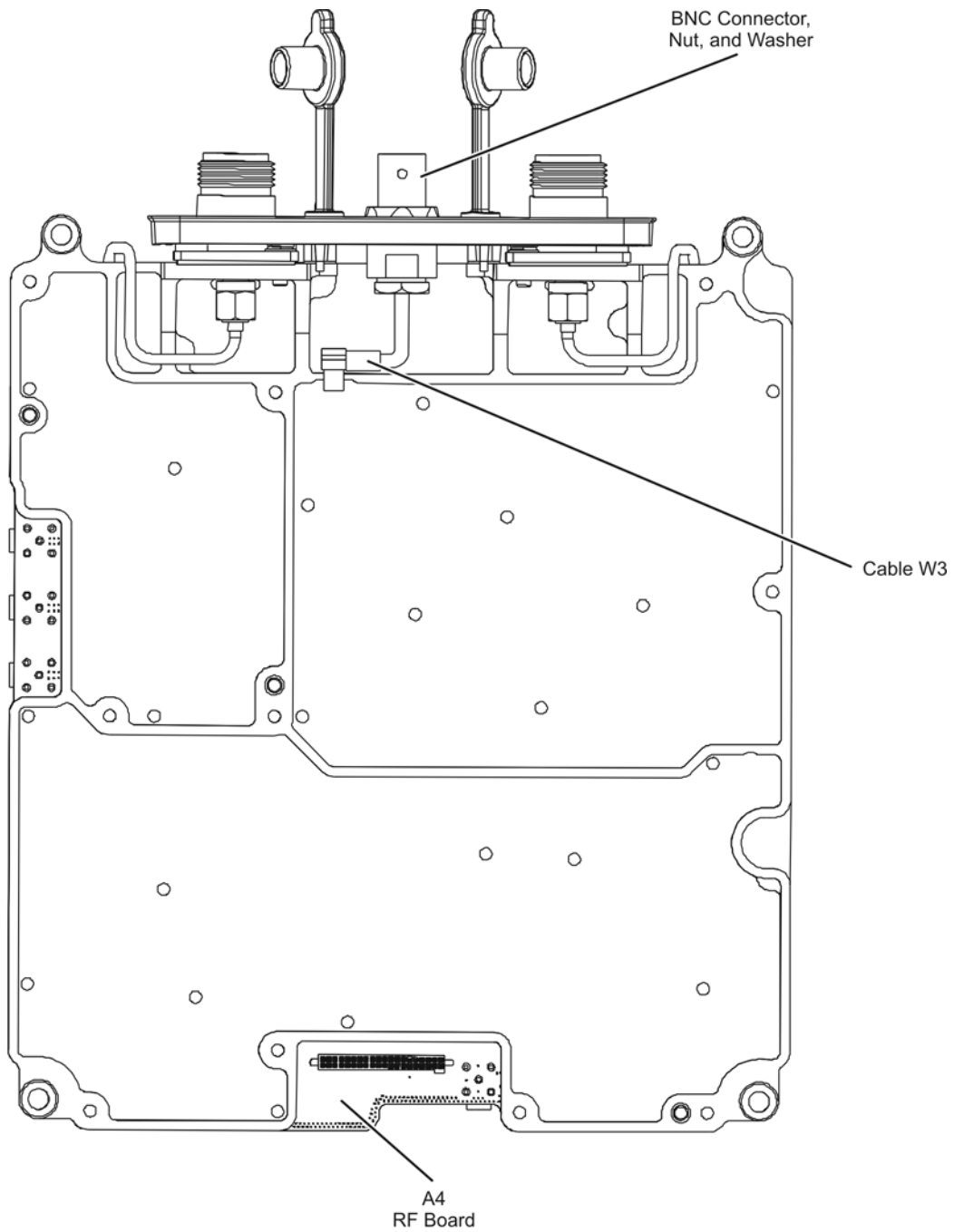

View of the RF Assembly After Removing the A5 System Board.

n9912_90003_722

Reinstalling All Measurement Group Assemblies as One Unit

1. Reinstall the I/O side panel, if needed. Refer to [“Replacing the I/O Side Panel, Doors, and Gasket”](#) on page 7-12.
2. Position the measurement group assemblies to the side of the front case as shown in [Figure 7-18](#) on page 7-26. Refer to [“Removing All Measurement Group Assemblies as One Unit”](#) on page 7-25.
3. Reconnect the LCD to system board cable at the system board connector and place a strip of adhesive tape over the connector to secure it. This strip of adhesive tape is provided in the [Repair and Re-assembly Kit](#). If necessary, refer to [“Replacing the A2 LCD, the LCD Shield, and LCD Cables”](#) on page 7-20.
4. Position the measurement group assemblies on top of the front case and align the I/O side panel in the groove in the front case being careful not to damage the gasket.
5. Position (tuck) the LCD to system board cable in between the LCD shield and the A5 system board so that it will not interfere with the cases when they are combined.
6. Reconnect the system board to front panel interface board cable at the front panel interface board connector as shown.

Figure 7-24 Replacing All Measurement Group Assemblies as One Unit

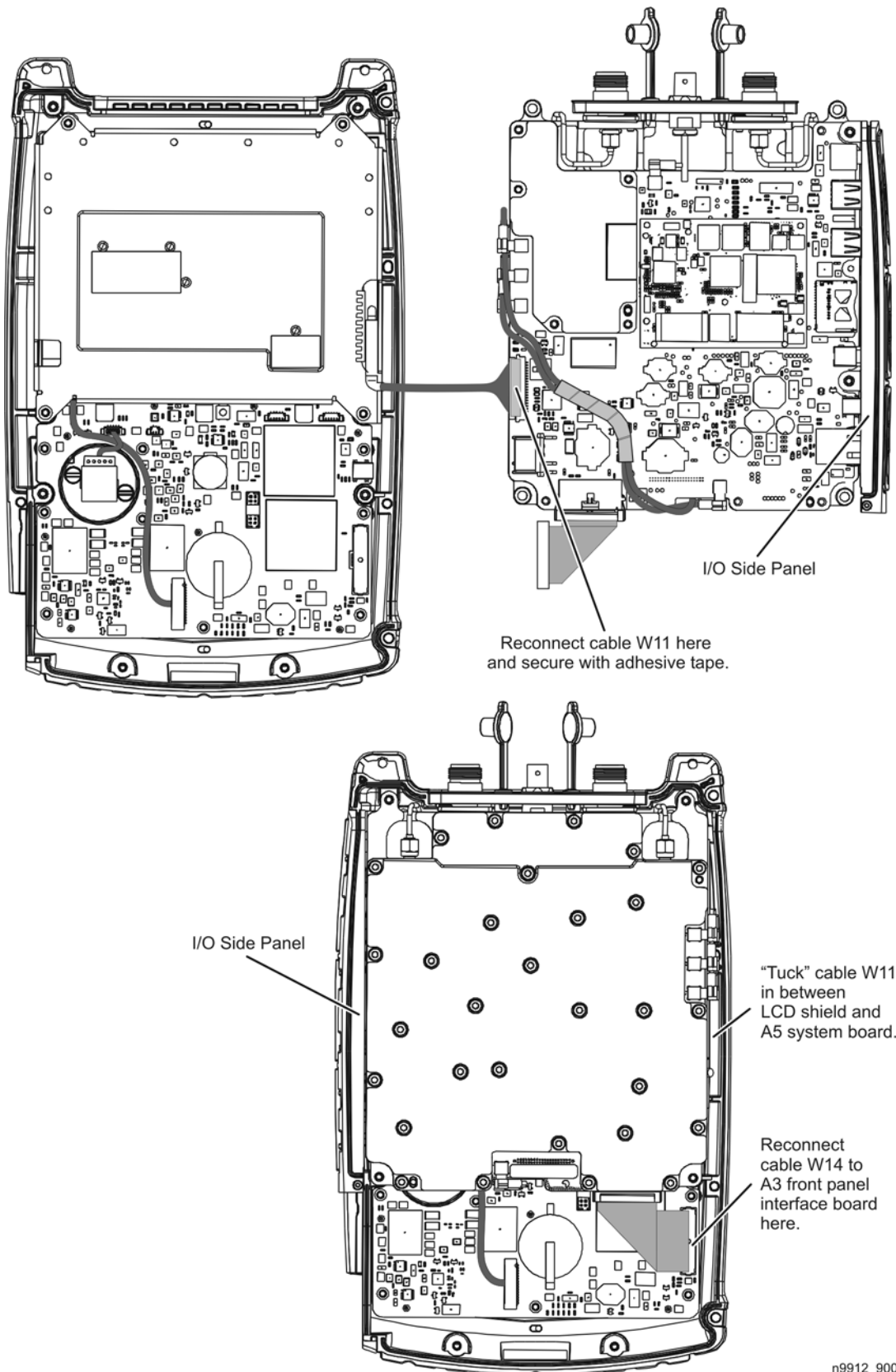

Post-replacement Procedure

1. Reinstall the measurement group assemblies into the front case. Refer to “[Reinstalling All Measurement Group Assemblies as One Unit](#)” on page 7-35.
2. Combine the front and rear cases. Refer to “[Combining the Front and Rear Cases](#)” on page 7-15.

Post-Repair Procedures

After the replacement of an assembly, you must perform the service procedures in the order listed in [Table 7-2](#).

Procedures referenced in this table are located in [Chapter 3, “Tests and Adjustments,”](#) unless specified otherwise.

Table 7-2 Related Service Procedures

Replaced Assembly	Adjustments, etc.	TME Tests or Other Procedures
Main battery	None needed.	None needed.
RPG	None needed.	Manual check of RPG operation.*
PORT 1 connector or associated cable (W1) replaced or disturbed.	Error Terms.	Error Terms test.
PORT 2 connector or associated cable (W2) replaced or disturbed.	Error Terms.	Error Terms test.
Front case (including A1 keypad)	None needed.	Manual check of keyboard.*
A2 LCD	None needed.	Manual check of LCD.*
A3 front panel interface board	None needed.	Manual check of keyboard.* Check for even brightness in LCD backlight.* Check sound.* Check time and date.*
A4 RF board	All TME based adjustments.	All TME based tests.
A5 system board	First, load the instrument serial number into the A5 system board.* All TME based adjustments.	All TME based tests. Check time and date.*
A6 SOM board	Install firmware from SD card.* Re-install options.* All TME based adjustments.	All TME based tests. Compare serial numbers.* Check time and date.*

* Refer to the following manual checks and procedures for details.

Manual Checks and Procedures

Manual Check of Keyboard

Check that each key works properly. Check that the keyboard backlight LEDs come on when a key is pressed.

Manual Check of LCD

Press **Service (7) > Display**, then use **Display Colors** and **Brightness** keys to exercise the display. Check for even brightness in the LCD backlight.

Manual Check of RPG Operation

Activate a marker and use the RPG to move the marker.

Load Instrument Serial Number into the A5 System Board

Instructions for this process may be accessed via the “Load instrument serial number into System Board” link at agilent.com/find/fieldfox2. (Follow the repair / calibration link.)

Install Firmware from SD Card

A specially configured SD card must be used when the flash memory on the A6 SOM board is new or when the A6 SOM board memory has become corrupted.

Instructions for creating and using the SD card are available at the “SD card for installing firmware” link at agilent.com/find/fieldfox2. (Follow the repair / calibration link.)

Compare Serial Numbers

Compare the serial number stored in the instrument memory with the serial number tag on the back of the instrument.

To access the stored serial number, press:

System (7) > Service Diagnostics > System Information

Check Sound

Attempt to set a frequency to a value of “.” (decimal point); a double beep should occur.

Re-Install Options

See the “[Service Related User Operations](#)” section of [Chapter 8](#) for information on re-installing options.

Check Time and Date

If time and date displayed in upper right-hand corner needs to be modified, press:

System > System Configuration

8 General Purpose Maintenance and Service Procedures

Information in This Chapter

Chapter Eight at-a-Glance

Section Title	Summary of Content	Start Page
Supplemental Information	Web site for additional service information that becomes available after printing of this manual.	page 8-3
Service Related User Operations	How to: <ul style="list-style-type: none">• view options currently installed on your analyzer• view the current firmware revision• view the error log• view temperature readings• erase user data	page 8-3
Options	How to: <ul style="list-style-type: none">• view the currently installed options• re-install options after repair	page 8-5
Firmware Upgrades	How to: <ul style="list-style-type: none">• check your analyzer's current firmware revision• where to locate additional information about firmware upgrades	page 8-6
Miscellaneous Service and Maintenance	Information about: <ul style="list-style-type: none">• cleaning the display• battery maintenance	page 8-7

Supplemental Information

Supplemental information for this service guide is available at:

http://na.tm.agilent.com/fieldfox/serv_guide_supplement.html

This web site contains additional service information and is updated as new information becomes available.

Service Related User Operations

To View Currently Installed Options

- Press **System(7)**.
- Press **System Configuration**.
- Press **Options**.
- Press **Show Options**.

A list of the currently installed options is displayed.

To View the Current Firmware Revision, Etc.

- Press **System(7)**.
- Press **Service Diagnostics**.
- Press **System Information**.

The System Information screen includes the following information:

- Model Number = instrument model number
- Serial Number = instrument serial number
- Firmware Release = version of installed firmware
- Network Identity = computer name and current IP address
- RF Serial Number = serial number of RF PCA
- SB Serial Number = serial number of System Board PCA
- FP Serial Number = serial number of Front Panel PCA
- User Data Erased = the most recent date and time User Data Erase performed

To View the Error Log

- Press **System(7)**.
- Press **Service Diagnostics**.
- Press **Error Log**.

See the “[Firmware Related Information](#)” section of [Chapter 5](#) for details on the error log.

To View Temperature Readings

- Press **System(7)**.
- Press **Service Diagnostics**.
- Press **Internal Temperatures**.

See the “[Temperature Related Information](#)” section of [Chapter 5](#) for details.

Erase User Data Utility

- Press **System(7)**.
- Press **Service Diagnostics**.
- Press **Advanced**.
- Press **Erase User Data**.
- Press **Confirm Erase**.

The User Data memory portion is erased, then the instrument restarts. See the “[Firmware Related Information](#)” section of [Chapter 5](#) for details on the Erase User Data utility.

Options

Installed options determine the functionality of the analyzer. There is a license associated with each option. Every instrument has at least one option installed, “104”, or “106”. This option determines the maximum frequency of the instrument. Additional options enable additional modes or other functionality.

Note that the maximum frequency of the instrument may not be “upgraded”. Option 104 or 106 is installed in the factory and may not be changed in the field.

To View Currently Installed Options

- Press **System(7)**.
- Press **System Configuration**.
- Press **Options**.
- Press **Show Options**.

A list of the currently installed options is displayed.

Re-Installing Options

If an instrument loses all of its options (i.e. it reports or “shows” no options), the only functionality available will be NA up to 4 GHz.

When the A6 SOM board is replaced, it is necessary to re-load the license files because the license and option information is stored on the A6 SOM board.

Process for obtaining and re-installing options:

1. Send an email to ctd-soco_support@agilent.com with the following information.
 - Indicate that you need previously issued licensed for a FieldFox repair.
 - Model number and serial number of the instrument.
 - Maximum frequency of the instrument from the label above the display.
 - A list of options from the serial number label on the back of the instrument.
 - A brief description of why options need to be re-installed. This information will help Agilent identify recurring problems that may need special attention.
2. Within two working days, you will receive an email response with a license file attached.
3. Copy the license file to the root of a USB flash drive. Follow the appropriate instructions in the N9923A Upgrade Installation Instructions.

Firmware Upgrades

To Check the Current Firmware Revision

- Press **System(7)**.
- Press **Service Diagnostics**.
- Press **System Information**.

The current firmware version is indicated on the “Firmware Release” line.

If the firmware upgrade process is interrupted, memory contents in the instrument may become corrupted. If a problem is suspected, consider doing a fresh installation of the firmware. Follow the process under “[Install Firmware from SD Card](#)” near the end of [Chapter 7](#).

See the “[Firmware Related Information](#)” section of [Chapter 5](#) for details on what happens during the firmware update process.

Miscellaneous Service and Maintenance

Cleaning the Display

Materials: Use a soft, lint-free cloth. Use a solution with 99.5% IPA (isopropyl alcohol) or a high quality window cleaning solution.

Technique: Do not rub back and forth with a polishing motion. Use a single swipe from the soiled location to the nearest edge of the display.

Battery Maintenance

See the “Working with the Lithium-Ion Battery” section of the *N9923A FieldFox RF Vector Network Analyzer User’s Guide* for information on the removable battery. In particular, see “Built-In Battery Gauge” and “Reconditioning the Battery”.

A

- A1 keypad**
 - illustrated, 6-5
 - part number, 6-5
 - removal and replacement, 7-6
- A2 LCD**
 - illustrated, 6-5
 - operation, 5-6
 - part number, 6-5
 - removal and replacement, 7-18
- A3 front panel interface board**
 - illustrated, 6-5
 - operation, 5-5
 - part number, 6-5
 - removal and replacement, 7-18
- A4 RF board**
 - operation, 5-7
- A5 system board**
 - operation, 5-10
 - removal and replacement, 7-25
- A6 SOM board**
 - operation, 5-13
 - removal and replacement, 7-25
- Agilent**
 - contacting, 2-6
 - support, 2-5
- analyzer**
 - miscellaneous replaceable parts
 - part numbers, 6-12
 - options, 2-3
 - system block diagram, 5-4
 - warmup time, 3-3
- ANSI Z540 standards compliant calibration, Option A6J, 2-5**
- assemblies**
 - replacement
 - cautions about, 7-4
 - list of procedures, 7-4
 - sequence, 6-4, 7-4
 - warnings about, 7-4

B

- battery**
 - cable
 - removal and replacement, 7-6
 - charging management, 5-16
 - information screen, 5-16
 - operation, 5-13, 5-16
 - temperature, 5-20
- battery disposal, 1-7**
- battery, main**
 - removal and replacement, 7-5
- battery, RTC**
 - removal and replacement, 7-18
- before applying power, 1-4**

C

- calibration**
 - ANSI Z540 standards
 - compliant, Option A6J, 2-5
 - commercial, Option UK6, 2-5
 - in CAT and NA modes, 5-21
 - ISO 17025 standards compliant, Option 1A7, 2-5
 - one port, 5-21
 - options available, 2-5
 - QuickCal, 5-21
 - two port, 5-21
 - types, 5-21
- care of connectors, 3-4**
- case group**
 - removal and replacement
 - procedure, 7-6
- cases**
 - removal and replacement, 7-6
- caution, 1-3**
- CE mark, 1-6**
- check**
 - operational, 3-6
- checklist**
 - before return to customer, 3-6
- checks and procedures**
 - manual, 7-38
- commercial calibration**
 - Option UK6, 2-5
- compare**
 - instrument serial numbers, 7-38
- connector**
 - care
 - principles of, 3-4
 - quick reference, 3-4
- connectors**
 - care of, 3-4
- contacting Agilent, 2-6**
- CPU board**
 - operation, 5-13
 - removal and replacement, 7-25
- CSA mark, 1-6**

D

- display**
 - illustrated, 6-5
 - operation, 5-6
 - parts list, 6-5
 - removal and replacement, 7-18
- documentation**
 - part numbers, 6-12
 - printing copies from the web, 2-6

E

- earth ground, 1-3**
- electrostatic discharge, *See ESD***

- equipment**
 - for service, 3-5
- erase user data utility, 5-23**
- error log, 5-23**
- ESD**
 - protection, 1-5, 3-3, 4-3, 7-3
 - supplies
 - part numbers, 6-12

F

- firmware**
 - check current revision of, 8-6
 - erase user data utility, 5-23
 - error log, 5-23
 - general description, 5-23
 - install from SD card, 7-38
 - operational files, 5-23
 - upgrades, 5-23
 - upgrading, 8-6
 - user accessible files, 5-23
- front panel**
 - replaceable parts
 - illustrated, 6-5
 - part numbers, 6-5
- front panel group**
 - operation, 5-5
 - troubleshooting, 4-7
- front panel group assemblies**
 - removal and replacement, 7-18
- front panel interface board**
 - illustrated, 6-5
 - operation, 5-5
 - part number, 6-5
 - removal and replacement, 7-18
- functional groups, 5-3**

G

- general safety considerations, 1-3**
- ground, safety earth, 1-3**
- grounding**
 - operation, 5-14

I

- instruction documentation**
 - symbol, 1-6
- instrument markings, 1-6**
- instrument serial number**
 - compare, 7-38
 - load, 7-38
- ISM1-A mark, 1-6**
- ISO 17025 standards compliant calibration, Option 1A7, 2-5**

K

keyboard

manual check, 7-38

keypad

illustrated, 6-5
part number, 6-5
removal and replacement, 7-18

kickstand

removal and replacement, 7-6

L

LAN interface

general information, 5-25

LCD

illustrated, 6-5
manual check, 7-38
operation, 5-6
parts list, 6-5
removal and replacement, 7-18

LCD shield

removal and replacement, 7-18

lithium battery disposal, 1-7

load

instrument serial number, 7-38

M

main battery

removal and replacement, 7-5

maintenance

battery maintenance, 8-7
cleaning, 2-3
cleaning the display, 8-7

manual check

keyboard, 7-38
LCD, 7-38
RPG, 7-38

manual checks and procedures, 7-38

measurement group

operation, 5-7
troubleshooting, 4-8

measurement group assemblies

removal and replacement, 7-25

miscellaneous replaceable parts

part numbers, 6-12

O

operating modes, 5-18

CAT and NA, 5-19
PM, 5-19

operation

A4 RF board, 5-7
A5 system board, 5-10
A6 SOM board, 5-13
battery, 5-13, 5-16

battery charging management, 5-16

CAT and NA modes, 5-19

CPU board, 5-13

front panel group, 5-5

front panel interface board, 5-5

grounding, 5-14

in modes, 5-18

LCD, 5-6

measurement group, 5-7

PM mode, 5-19

power, 5-14

power control, 5-14

power management, 5-14

power states, 5-14

power supplies, 5-14

smart power management, 5-14

theory of, 5-3

operational check, 3-6

operational files, 5-23

option

calibration, 2-5

service and support, 2-5

Option IA7

ISO 17025 standards compliant
calibration, 2-5

Option A6J

ANSI Z540 standards compliant
calibration, 2-5

Option UK6

commercial calibration, 2-5

options

analyzer, 2-3

re-installing options, 8-5

view currently installed options, 8-5

ordering information

replaceable parts, 6-3

P

part numbers

documentation, 6-12

repair and reassembly kit, 6-12

replaceable parts

in front panel assembly, 6-5

miscellaneous analyzer, 6-12

supplies

ESD, 6-12

tools

service, 6-12

parts

in front panel

illustrated, 6-5

in front panel assembly

part numbers, 6-5

miscellaneous

part numbers, 6-12

replaceable

listing of, 6-5

ordering information, 6-3

post-repair procedures, 7-37

power

control, 5-14

management, 5-14

operation, 5-14

smart management

operation, 5-14

states, 5-14

supplies, 5-14

pre-repair

procedures

caution about, 7-3

warnings about, 7-3

printing documentation from the web, 2-6

protection

against ESD, 1-5, 3-3, 4-3, 7-3

Q

QuickCal, 5-21

R

removing

assemblies, *See specific assembly.*

parts, *See specific part.*

repair

post-repair procedures, 7-37

procedures

caution about, 7-3

warnings about, 7-3

repair and reassembly kit

contents, 6-12

part number, 6-12

replaceable parts

in front panel

illustrated, 6-5

in front panel assembly

part numbers, 6-5

listing of, 6-5

miscellaneous analyzer

part numbers, 6-12

ordering information, 6-3

replacement

A1 keypad, 7-6

A2 LCD, 7-18

A3 front panel interface board, 7-18

A5 system board, 7-25

A6 SOM board, 7-25

assembly

cautions about, 7-4

list of procedures, 7-4

sequence, 6-4, 7-4

- warnings about, 7-4
- case group
 - procedure, 7-6
- CPU board, 7-25
- front panel group assemblies, 7-18
- LCD shield, 7-18
- main battery, 7-5
- measurement group assemblies, 7-25
- RF assembly, 7-25
- RF connectors, 7-25
- RF top assembly, 7-25
- RPG, 7-18
- RPG knob, 7-18
- RTC battery, 7-18
- replacement sequence**, 4-3
- returning to customer**
 - checklist, 3-6
- RF assembly**
 - removal and replacement, 7-25
- RF board**
 - operation, 5-7
- RF connectors**
 - removal and replacement, 7-25
- RF top assembly**
 - removal and replacement, 7-25
- RPG**
 - manual check, 7-38
 - removal and replacement, 7-18
- RPG knob**
 - removal and replacement, 7-18
- RTC battery**
 - removal and replacement, 7-18

S

- safety**
 - considerations, 1-3
 - earth ground, 1-3
 - symbols, 1-3
- screen**
 - temp, 5-20
- SD card**
 - used to install firmware, 7-38
- service**
 - battery maintenance, 8-7
 - cleaning the display, 8-7
 - contacting Agilent, 2-6
 - erase user data utility, 8-3
 - options, 2-5
 - procedures
 - caution about, 7-3
 - post-repair, 7-37
 - warnings about, 7-3
 - related user operations, 8-3
 - static safety parts
 - part numbers, 6-12

- tools
 - part numbers, 6-12
- view current firmware revision, 8-3
- view currently installed options, 8-3
- view temperature readings, 8-3
- view the error log, 8-3
- warranty
 - standard, 2-5
 - three-year return to Agilent, 2-5
- service test equipment**, 3-5
- shipment for service or repair**, 2-6
- smart power management**
 - operation, 5-14
- SOM board**
 - operation, 5-13
- standards compliant calibration**
 - ANSI Z540, Option A6J, 2-5
 - ISO 17025, Option 1A7, 2-5
- strap handle**
 - removal and replacement, 7-6
- supplies**
 - ESD
 - part numbers, 6-12
- support**
 - contacting Agilent, 2-6
 - options, 2-5
 - organization, 2-5
- system board**
 - operation, 5-10

T

- temperature**
 - battery pack, 5-20
 - related information, 5-20
 - screen, 5-20
- test equipment**
 - service, 3-5
- tools**
 - service, part numbers, 6-12
- troubleshooting**
 - front panel group, 4-7
 - measurement group, 4-8
 - power up, 4-6
 - where to begin, 4-4

U

- upgrades**
 - firmware, 5-23
- user accessible files**, 5-23
- user data**
 - erase utility, 8-3

V

- view**
 - current firmware revision, 8-3
 - currently installed options, 8-3, 8-5
 - temperature readings, 8-3
 - the error log, 8-3

W

- warm up**
 - analyzer, 3-3
- warning**, 1-3
- warranty**
 - service
 - standard, 2-5
 - three-year return to Agilent, 2-5

